





# BAT examples from the Nordic iron and steel in- dustry

*Nils-Olov Lindfors and Pertti Kostamo*

## **BAT examples from the Nordic iron and steel industry**

2006:410

© Nordic Council of Ministers, Copenhagen 2005

### **Nordic Council of Ministers**

Store Strandstræde 18  
DK-1255 Copenhagen K  
Phone (+45) 3396 0200  
Fax (+45) 3396 0202

### **Nordic Council**

Store Strandstræde 18  
DK-1255 Copenhagen K  
Phone (+45) 3396 0400  
Fax (+45) 3311 1870

**[www.norden.org](http://www.norden.org)**

## **Nordic co-operation**

Nordic co-operation, one of the oldest and most wide-ranging regional partnerships in the world, involves Denmark, Finland, Iceland, Norway, Sweden, the Faroe Islands, Greenland and Åland. Co-operation reinforces the sense of Nordic community while respecting national differences and similarities, makes it possible to uphold Nordic interests in the world at large and promotes positive relations between neighbouring peoples.

Co-operation was formalised in 1952 when *the Nordic Council* was set up as a forum for parliamentarians and governments. The Helsinki Treaty of 1962 has formed the framework for Nordic partnership ever since. The *Nordic Council of Ministers* was set up in 1971 as the formal forum for co-operation between the governments of the Nordic countries and the political leadership of the autonomous areas, i.e. the Faroe Islands, Greenland and Åland.

# Contents

<b>Contents</b>	<b>5</b>
<b>Preface</b>	<b>7</b>
<b>Summary</b>	<b>9</b>
<b>Swedish Summary - Sammanfattning</b>	<b>11</b>
<b>Introduction</b>	<b>15</b>
<b>Project objectives</b>	<b>17</b>
<b>Comments on the present BREF's (2001)</b>	<b>19</b>
Production of Iron and Steel (BREF I)	19
Comments	19
Comments regarding dioxin formation and emissions	20
ITMK3 - Description	21
Updating of LKAB pelletizing processes	22
Ferrous metals processing industry (BREF II)	28
Comments	28
Additional comments and notes	28
Castrip process update	29
<b>Presentation of BAT-examples from the Nordic Iron and Steel Industry</b>	<b>31</b>
Criteria for selection of objects	31
Presentation of the project description work, selection of the final objects	31
<b>References of the objects</b>	<b>32</b>
Positioning of the objects	32
Objects in the BREF I – Production of Iron and Steel (Established techniques)	33
Objects in the BREF I – Production of Iron and Steel (Emerging techniques)	45
Objects in the BREF II – Ferrous metals processing industry (Established techniques)	47
Objects in the BREF II – Ferrous metals processing industry (Emerging techniques)	54
<b>Descriptions of the objects</b>	<b>57</b>
Objects in the BREF I – Iron and steel production (Established techniques)	57
Objects in the BREF I - (Emerging techniques)	91
Objects in the BREF II - (Established techniques)	95
Objects in the BREF II - (Emerging techniques)	117
<b>Evaluation of the selected objects from the BAT point of view</b>	<b>125</b>

**Conclusions**

**127**

**Appendices**

**129**

1. Working procedure in the project
2. Explanations for abbreviations and other special terminology
3. Descriptions of the companies and plants

# Preface

Nordic reports on low environmental impact technology for different industrial areas are prepared under the direction of the Nordic BAT-group. The Nordic BAT-group in turn falls within the remit of the Products and Waste Working Party (the PA group) of the Nordic Council of Ministers. The BAT-group commissions Nordic consultants in selected industrial sectors, to carry out reporting works (BAT-projects) for the Nordic Council of Ministers.

This report deals with “production of iron and steel” and “ferrous metals processing industry”, and is the final report of the corresponding BAT-BREF-project. The main purpose of this study is to support for the coming updating work of the BREF’s in question, and also to promote the possibilities to include Nordic examples in these BREF-areas.

The project was carried out by MEFOS - Metallurgical Research Institute AB in Luleå, Sweden. The person responsible at MEFOS Nils-Olov Lindfors, M.Sc. recruited Pertti Kostamo, Tech. Lic. (retired from Rautaruukki OYJ) to participate in the project.

The work was supervised by the following Nordic BAT-group members: Jari Gidlund (chairman), May Anita Dolmseth Hoel, Stefan Einarsson, Erkki Kantola, Johanna Olsen, Ulla Ringbaeck and Susanna Särs.

Luleå 16 June 2005

Nils-Olov Lindfors



# Summary

The Nordic Ministry Council has via its PA-group (Products and Wastes) decided to make a Nordic study concerning good BAT-level objects in the Nordic iron and steel production and ferrous metals processing.

The aim of this study is to support the coming updating work of the present (2001) BREF's in the corresponding areas. The practical work was done by MEFOS - Metallurgical Research Institute AB, Sweden with a timetable for completion of March 31, 2005. The Nordic BAT-group was acting as steering group. This study made it very clear, that there are a lot of BAT-level processes, sub-processes, measuring technologies etc. in both areas. The work was carried out in close co-operation with the representatives of the industry. The basic objective was to present a total of about 20 objects. The study has resulted in a much more extensive number of objects and includes a total of 35 objects, which are rather well divided into the "steel production" and "ferrous metals processing" areas. Of the total of 35 objects, 27 belong to the list "Established techniques" and 8 to the list "Emerging techniques". 3 of the objects are collective and include 19 sub-objects. This makes a grand total of 51 individual objects. All the objects are listed in the following table.

In addition to the new descriptions of the Nordic BAT-level objects the both present BREF's are commented from today point of view.



# Swedish Summary - Sammanfattning

Det nordiska ministerrådet har via sin PA-grupp (Produkter och avfall) beslutat att genomföra en nordisk studie av goda BAT-nivå objekt i den nordiska järn- och stålproduktionen samt inom vidareförädling av stål.

Målet med studien är att stödja det kommande arbetet med att uppdatera nuvarande BREF-dokument (2001) inom motsvarande områden. Det praktiska arbetet har utförts av MEFOS – Metallurgical Research Institute AB, Sverige och avslutades 2005. Den nordiska BAT-gruppen har fungerat som styrgrupp. Studien har klargjort att det finns många BAT-nivå processer, underprocesser, mättekniker etc. i båda områdena. Arbetet har utförts i nära samarbete med representanter från industrin. Målet var att presentera ca 20 objekt. Studien har resulterat i ett mycket större antal och inkluderar totalt 35 objekt som är ganska lika fördelade i grupperna ”iron and steel production” samt ”ferrous metals processing industry”. Allt som allt utgör detta 51 objekt. Av totalt 35 objekt tillhör 27 stycken listan över ”Established techniques” och 8 stycken tillhör ”Emerging techniques”. 3 av objekten är kollektiva och inkluderar 19 underobjekt. Samtliga objekt är listade i följande tabell.

Förutom beskrivningar av nya nordiska BAT-nivå objekt har innehållet i de båda befintliga BREF-dokumenterna kommenterats.

<b>BREF</b>	<b>OBJECT</b>	<b>EMERG</b>	<b>Title of the object</b>	<b>Reference plant</b>	<b>BREF position</b>
I	1.1		Nordic practice for District Heating - Using waste heat from the steel industry	Ovako Hofors	I.9.2,EP2
I	1.2		Nordic practice for District Heating - Production of municipal district heating with steel works waste heat	Ruukki production, Raahe Works	I.4.3.1,PI2
I	1.3		Nordic practice for District Heating - District heating Luleå	SSAB Tunnpå AB, Luleå Works	I.7.3, PI.2
I	2		Low CO <sub>2</sub> emissions from magnetite based iron ore pellets production	LKAB Kiruna	I.5.2
I	3		Process-integrated NO <sub>x</sub> abatement	LKAB Kiruna	I.5.3,PI.2
I	4.1		Nordic Blast Furnace practice - Oxy-oil technology	Ovako Koverhar	I.7.1.4
I	4.2		Nordic Blast Furnace Practice - The use of models for controlling of the wear in blast furnace hearth	Ovako Koverhar	(I.7.1)
I	4.3		Nordic Blast Furnace practice - Dry-quenching practice at coke production	Raahe Works	I.6.3,PI.7
I	4.4		Nordic Blast Furnace practice - Low slag volume blast furnace practice using sinter as raw material	Ruukki production, Raahe Works	I.7.1
I	4.5		Nordic Blast Furnace practice - Recovering of heat from the cowpers	Ruukki production, Raahe Works	I.7.3,PI.4, I.7.5
I	4.6		Nordic Blast Furnace practice - Oxy-coal-injection technique at the blast furnace	SSAB Oxelösund AB	I.7.1.4
I	4.7		Nordic Blast Furnace practice - 100% pellets operation at the blast furnace	SSAB Oxelösund AB	I.7.1
I	4.8		Nordic Blast Furnace practice - Low slag volume using 100% pellets	SSAB Oxelösund AB	I.7.1
I	4.9		Nordic Blast Furnace practice - Briquettes - a way to be independent of a sinterplant to recycle inplant fines	SSAB Oxelösund AB	I.5.5.2
I	4.10		Nordic Blast Furnace practice - 100% pellets operation	SSAB Tunnpå AB, Luleå Works	I.7.1
I	4.11		Nordic Blast Furnace practice - Low slag volume using 100% pellets	SSAB Tunnpå AB, Luleå Works	I.7.1
I	4.12		Nordic Blast Furnace practice - Briquettes - a way to recycle inplant fines	SSAB Tunnpå AB, Luleå Works	I.5.5.2
I	5		Utilization of ironmaking and steelmaking slags as products	Ruukki production, Raahe Works	I.7.1.6.1
I	6		Automatic ladle lid system	Ruukki production, Raahe Works	(I.8.1)
I	7		Automated BOF tapping practice	SSAB Tunnpå AB, Luleå Works, Ruukki Production, Raahe Works	(I.8.1)
I	8		Continuous measurement of dust emissions from secondary dedusting system	SSAB Oxelösund AB	I.8.2.2.1.1.3
I	9		Direct tapping from BOF	Ovako Koverhar	I.8.3,PI3
I	10		Efficient use of big amounts of scrap in converter process and efficient utilization of scrap arising at the works	Ruukki production, Raahe Works	I.9.1.1
I	11		Filter plant service and monitoring system	Ovako Imatra	I.9.2.2.1
I	12		Avoiding dust formation when emptying slag pots	AB Sandvik Materials Technology	I.9.1.7
I	13		Determination of some environmental sensitive elements in waste water	AB Sandvik Materials Technology	I.9.2.2.3
I	14		Biological waste water treatment at coking plant	SSAB Tunnpå AB, Luleå Works	I.6.3,EP11
I	1	E	Frequency-converted control of pumps and fans for cooling and cleaning water, and for the off-gas suction system at the LD-process	SSAB Oxelösund AB	I.8.5, I.8.2.2.4
I	2	E	Burning and recycling of dry waste dusts (Radust process), pilot plant	Ovako Koverhar	I.8.5
I	3	E	Production of stainless steel slag products	Outokumpu Stainless, Tornio Works	I.9.5, I.9.1.7

BREF	OBJECT	EMERG	Title of the object	Reference plant	BREF position
II	1		Hot charging of blooms into the reheating furnace	Ovako Imatra	II.A.4.1.3.17
II	2		Environmentally sound and energy efficient reheating of steelbillets in a mini-mill reheating furnace	Ruuki production, Fundia Mo-works.	II.A.3.1.3
II	3		Mandrelless coilbox	Ruukki production, Raahe Works	II.A.4.1.7.1
II	4		Oxy Fuel Technology for heating operations	Outokumpu Stainless, Avesta Works	II.A.4.1.3.6
II	5		Turbulence-pickling for the continous pickling line for carbon steel	Ruukki production, Hämeenlinna Works	II.A.4.2.2.5
II	6		Increased productivity through turbulent pickling	Outokumpu Stainless, Avesta Works, Nyby, Degerfors	II.A.3.2.2
II	7		SCR Technology for NOx reduction in pickling line	Outokumpu Stainless, Tornio Works	II.A.4.2.21,II.D.2.4
II	8		NOx suppression by injection of hydrogen peroxide (H <sub>2</sub> O <sub>2</sub> )	Outokumpu Stainless, Coil products Nyby,	II.A.4.2.2.20, II.D5.8.1
II	9		OSAR-practice - Outokumpu Sulfurdioxide Aided chromium Reduction	Outokumpu Stainless, Tornio Works	(II.A.3.2.2)
II	10		OPAR - Outokumpu Pickling Acid Recovery system	Outokumpu Stainless, Tornio Works	II.A.3.2.3
II	11		Acid recycling by electrodialysis	Outokumpu Stainless, Coil products Nyby, Torshälla	II.A.4.2.2.1
II	12.1		Nordic Hot Dip (batch) Galvanizing: Hot dip galvanizing at JIWE	JIWE Varmförzinkning AB	II.C.3
II	12.2		Nordic Hot Dip (batch) Galvanizing: The pretreatment process at hot dip galvanizing	Dansk OverfladeTeknik A-S	II.C.4.2.4, II.C.4.3.3
II	12.3		Nordic Hot Dip (batch) Galvanizing: Powder coating of hot dip galvanized steel products	Ørsta Stål As	(II.C.2.10)
II	12.4		Nordic Hot Dip (batch) Galvanizing: Filtration of gases/fumes from hot dip galvanizing bath	Galvanoimis OY	II.C.4.6
II	13		Roll coater in the passivation of the hot dip galvanized strip	Ruukki production, Hämeenlinna Works	II.B.6.1.1
II	1	E	Endless rolling practice for demanding wire-rod products	Ovako Dalsbruk	II.A.6.1.4.1
II	2	E	Sequential impulse firing burner technology in the reheating furnace in the hot strip mill	Ruukki production, Raahe Works	II.A.6, II.A.4.1.3.2
II	3	E	Processing of hydroxide sludge from stainless steel pickling to a usable slag former in the melting shop	Outokumpu Stainless, Avesta Works	II.A.6, II.A.4.2
II	4	E	Passivation with Cr <sup>6+</sup> -free products in the continous hot dip galvanizing line	Ruukki production, Hämeenlinna Works	II.B.6.1.3
II	5	E	Advanced SCR-application for NOx reduction in the annealing line	SSAB Tunnpå AB, Borlänge	II.D.2.4



# Introduction

The reference documents for this study are two present BREF's

- BREF on the production of iron and steel, 2001(later BREF 1).
- BREF on the ferrous metals processing industry, 2001(later BREF 2).

These BREF's have been worked out according to the IPPC (Integrated Pollution Prevention and Control) directive given by the European Commission.

The background material for the present BREF's is from the 1990's (average about 1995) and the documents were finalized by the technical working groups (TWG's) in the year 2001 after about 2 years of working.

The decision was made by the Commission that both of these BREF's shall be updated. According to the latest information, the updating work is going to start at the beginning of the year 2006. The aim of the Nordic BAT-BREF project is to give the best possible support from the Nordic countries to the BREF-updating work. This includes comments on the existing documents and presenting good Nordic examples aimed to be included in the updated BAT-BREF documents.



# Project objectives

The main objective of the project was to formulate the best possible supporting material from the Nordic countries for the upcoming BREF-updating work. The main sub-goals for the project were:

- To build a well researched document with good examples of BAT-level-objects in the Nordic countries.
- To work out the present data concerning especially the environmental impact and the energy efficiency of the objects.
- To clarify the Nordic synergies in BAT processes and other techniques.
- To build a Nordic network of persons and organisations in the case of questions.
- The focus of the objects selected was for practices with “Established techniques”, but it was seen as important to include some objects considered “Emerging techniques”, which are being established in the near future.
- The preliminary target for the number of the objects was about 15 on the list of “Established techniques” and about 5 objects on the list of “Emerging techniques”.
- Another objective was to comment the present BREF’s.



# Comments on the present BREF's (2001)

## Production of Iron and Steel (BREF I)

### Comments

- The focus on CO<sub>2</sub> emissions has increased remarkably.
- The importance of rest product utilization is becoming more and more essential.
- Over a number of years a lot of attention has been put on the future coke making technology. The reason is that this question is of a strategic nature for Europe. We believe that differences in environmental impact and energy efficiency between different coke making technologies should be evaluated. Such an evaluation would promote the possibilities for further investments in coke making.
- The roles of process, production control and process modelling have a great influence on environmental impact and energy efficiency and should therefore be included in the future documents.
- Comments to the existing BREF-document regarding emissions of mercury from Electric Arc Furnace plants.

In existing document, Table 9.1 on page 281, mercury emission levels between 6-4470 mg/ton liquid steel is presented. The average value for four German EAF plants reported to be 370 mg per ton of liquid steel. The extremely big variation in the emission level should be studied. The lowest value, 6 mg per ton liquid steel, is however wrong. The correct value should be 60 mg per ton of liquid steel. Ref. Jernkontoret, B. Lindblad.

The present average mercury emission levels in the Nordic EAF plants vary between 60-200 mg per ton of liquid steel. The mercury emission from EAF plants originates mainly from pollutants in the scrap.

In the steel industry, scrap qualities and steel products are related because the lower priced steel qualities in general are based on the most contaminated scrap qualities, while high-quality steel producers are dependent on high quality scrap, which also is higher priced. It is, in general, therefore assumed that the mercury problem is less relevant for steel plants producing higher steel qualities.

The Nordic authorities have for a long time recognized the problem with mercury in the environment and the consequences for human health. Bans on use of the metal in different applications have been introduced during the last decades. Another consequence is that the Nordic scrap dealers have been working intensively with the removal of unwanted substances in the steel scrap. This has also been performed by owners of shredder plants and they have also in cooperation with the steel plants financed research and education projects within this area. All professional suppliers to

the shredders are educated to remove pollutants in the scrap before it is delivered to the shredder. That means among other things, that all mercury containing devices, like switches and relays, should be removed.

Another and important reason for lowering the mercury content in the scrap in a longer term is the strictly controlled usage of mercury in today's industrial products. In practice this means a strongly limited and eliminated usage of mercury in the products. The automobile industry is a good example in this matter.

In Norway it is reported that a great number of tests with smelting of scrap from selected sources and selected suppliers, in combination with continuous monitoring of mercury in the waste gas, were done with the objective to check if the problem could be reduced by eliminating scrap from certain suppliers. About 50 % of the scrap consumption of the plant is imported from other European countries. The study showed that such eliminations would not be sufficient to avoid the mercury variations between each charge.

Tests of mercury filtration were also conducted using a by-pass stream in a scrap-based steel plant in Norway. However, installation and operation of mercury filters for EAF plants would be costly due to the high gas flow volumes when producing steel.

Based on the work carried out in the Nordic countries, the following actions are recommended:

- Emissions of mercury from the secondary steel industry should be examined systematically on a European basis, with emphasis to find variations of mercury content in the scrap and other sources as coal, oil etc.
- Study the effects of restrictions for limited or eliminated usage of mercury in industrial products.
- The national authorities should require reporting of the pollution load of mercury in kg per year or gram per ton of steel. Reporting of concentration of mercury in waste gas is not sufficient in order to get a survey of the problem.
- Based on the results from above mentioned studies, it should be considered what actions that are appropriate to take, to reduce the influence of mercury in input materials.

### Comments regarding dioxin formation and emissions

The Swedish Environmental Protection Agency published a report on the dioxin situation in the country, 2005-03-31, Report no. 5462. The report shows that the emissions from the steel industry have been reduced since the 1980-ies, when measurements on dioxin started. The decrease in emissions are related to improved dust cleaning from the processes and improved process technologies. Also the shut down of the sintering plant in SSAB, Oxelösund made a strong contribution to lowering the dioxin emissions from the steel industry of Sweden. The mechanism for creation of dioxin in scrap melting had a focus in the Swedish Ironmaster Association research during the 1985-1995. The presented data for emissions to air is showed below:

Pellet plants	1.4-3	g TEQ/year
Primary Iron & Steel	1.5-2.6	“
Scrap based Iron & Steel	3	“

The focus on dioxin in several industrial areas is still essential due to that the exposure of dioxin to 10 % of Swedish people still is close to the maximum daily intake that has been set by the European Community. The situation in the other Nordic Countries is probably similar.

Based on the work carried out in the Nordic countries, the following actions could be considered, from the steel industry point of view:

Increase the data on dioxin emissions from steel industry, to get a better description of the actual situation in Europe. Also other industrial sectors must do the same inventory as for steel industry.

- Reduction of dust emissions, for all European countries to a Nordic level. Since lots of dioxin emissions are bounded to particles in the dust, improved dust cleaning, post combustion and quenching will lead to a decrease dioxin emissions. The dust emission from Nordic steel plants is on a level of 5-10 mg/m<sup>3</sup>.
- Further improvement of process technology. For example scrap preheating at higher temperature, improved filtration techniques, post combustion and gas quenching will lead to an improved situation. These technologies are to a great extent under emerging technologies and must be further developed.
- Study of dioxin emissions in sintering plants and pelletizing plants in Europe.
- Study of the dioxin balance for Europe. All countries in Europe should make a balance of import and export of dioxin to study the transport of dioxin between countries.
- Into this chapter is also included:
  - A new ironmaking process, ITmk3.
  - Pellet plants updating at LKAB in Kiruna.

#### ITMK3 - Description

- Belongs to BREF I / Chapter 10: New alternative ironmaking techniques.
- New techniques: ITmk3-process.
  - The ITmk3 is one of a number of new processes that are under development. This process has been selected as a good example. The process produces pure iron nuggets directly from fine iron ore and fine coal.

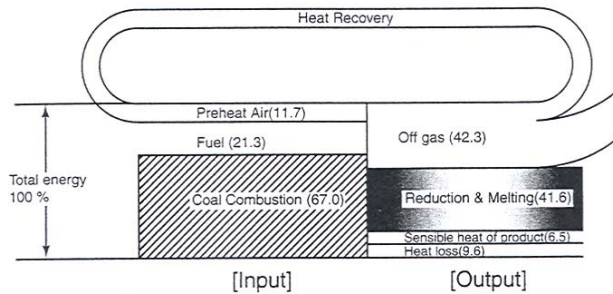

Figure 1. Heat balance of ITmk3 ® process (presented by Hidetoshi Tanaka at MEFOS's conference SCANMET II, 6-9 June 2004, Luleå, Sweden)

The furnace type is rotary hearth furnace, RHF.

The process feature is a rapid separation of iron metal and slag at very fast reduction and melting rate under a relatively low temperature (approximately 1450 °C) in the RHF.

The product is “iron nuggets” with an iron content of 97-98 % and with a metallization rate of more than 99 %. The carbon content of the “nuggets” is about 1.5 %, i.e. reasonably low.

ITmk3 is an environmentally friendly process, where a part of the sensible heat of the gas is recovered and recycled to the heat input as a preheated air. The estimated CO<sub>2</sub>-emissions of the route ITMK3 – EAF are reduced by 20-25 % compared with BF – BOF –route.

- Reference plant: A pilot demonstration plant for 25 000 t yearly production, located at Silver Bay, Minnesota (USA).
  - The first “iron nuggets” were produced on May 24, 2003.

In parallel with the PDP-operation, preparations to build a 500 000 t/y commercial plant has started.

- Reference: The presentation at the Scanmet II-conference, Luleå, June 2004.

### Updating of LKAB pelletizing processes

Pelletisation and sintering of iron ore are complementary process routes for the preparation of iron oxide raw materials for primary iron and steel making. Each has its own specific advantages and drawbacks. These are highly influenced by local conditions such as the availability and type of raw materials. For various reasons, sinter is practically always produced at the steel works side: it allows solid wastes to be recycled; coke breeze is available at steel works for use as a fuel; sinter is prone to degradation during transport and handling. Pellets are formed from the raw materials fine ore and additives of < 0.05 mm-into 9-16 mm spheres using very high temperatures and this is mainly carried on at the site of the mine or its shipping port. In the EU 15 there is only one integrated steel works which includes a pelletisation plant (in the Netherlands). Sweden has five stand-alone pelletisation plants.

Pellet production in the six EU plants mentioned above was 20 Mt in 2004. In 2004 total pellet consumption in the EU 15 was about 35 Mt whereas sinter consumption was three times higher.

## Applied processes and techniques

Pellets are small crystallized balls of iron ore with a size of 9-16 mm. Figure 1 shows the balling drum, which is part of a pelletisation plant.

The pelletisation process consists of grinding and drying or de-watering, balling and induration followed by screening and handling (Figure 2).

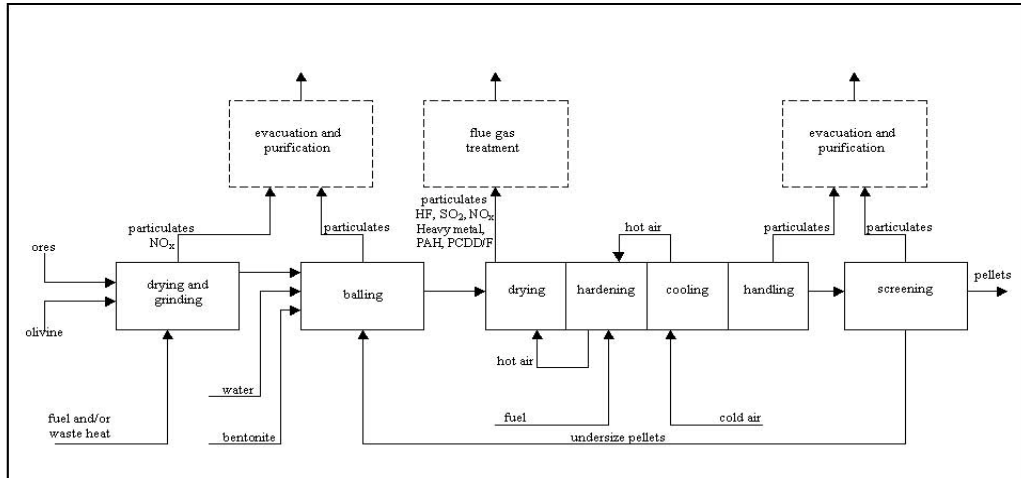

Figure 2. Schematic of a pelletisation plant [InfoMil, 1997].

### *Grinding and drying/de-watering*

Before being fed into the pelletisation plant the ore is upgraded by several sorting and beneficiation steps with intermediate crushing and grinding. The properties of the ore make magnetic separation the predominant means of concentrating. At the Swedish plants, grinding and concentration are wet processes. In the Dutch plant grinding is carried out at relatively high temperatures (approximately 100 °C). In the wet process additives (olivine, dolomite, bentonite, quartzite, and/or limestone depending on the end product and organic compounds as collectors) are ground and then added to the ore slurry, typically at a level of 3 to 3.5 %, before de-watering. In the other process after hot grinding the material is re-wetted in paddle-type mixers and combined with additives. In both cases the moisture content is adjusted to 8-9 %.

### *Green ball preparation*

De-watered or re-wetted pellet feed is mixed with additives and then processed in the (green) ball preparation plant. This is typically equipped with 4 to 6 balling circuits consisting of a feed bin, balling drum, roller screens and conveyors for circulating the materials. The balling drum is inclined 6 to 8° to the horizontal plane. To obtain a well defined green ball size, typically in the range 9 to 16 mm, under- and oversized fractions are screened off and re-circulated.

### *Induration*

Induration, which means thermal treatment, consisting of drying, heating and cooling. It can be carried out in two different systems; in 'straight grate' or 'grate kiln' systems. During thermal treatment magnetite is almost completely oxidized to hematite. This

contributes to the large amounts of heat needed to operate the process. The oxidation of magnetite is exothermic and contributes to 60 % of the energy needed for pelletization

The straight grate process

The straight grate process consists of a travelling grate divided into a number of different sections (Figure 3).

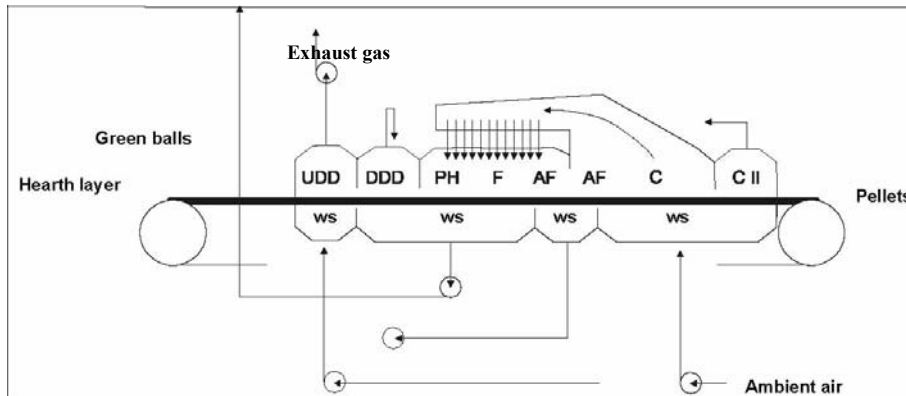

Figure 3. Schematic of the straight grate process at LKAB, Malmberget, Sweden.

- UDD up-draught drying with hot air from C II.
- DDD down-draught drying with hot air from AF.
- PH preheating with recuperated hot air from C.
- F firing zone oil and hot air from C.
- AF after firing sections with hot air from C.
- C cooling section using cool (ambient) air.
- C II second cooling section using cool (ambient) air.

Before the green balls are fed onto the grate bars, the bars are covered with a 5 to 10 cm thick hearth layer of fired pellets. The green balls are then charged on top of the hearth layer to form a gas permeable bed with a total depth of 40-55 cm. The green balls must be heated to approximately 1 250 °C during oxidation and sintering to obtain pellets with high strength. This can be achieved by means of a row of burners on each side of the travelling grate, usually fired with oil. At the end of the induration strand a fraction of the pellets are recycled for use as the hearth layer.

The grate kiln process

The grate kiln system consists of three main parts: a travelling grate, a rotary kiln, and a separate annular cooler.

The grate consists of an endless chain of grate plates which are connected with windboxes in a gas tight manner. The green balls are fed directly onto the grate plates to create a bed about 20-25 cm deep. After pre-treatment on the grate, the pellets are charged via a chute to the rotary kiln. The kiln a single oil- or coal-fired burner at the discharge end, and operates at a temperature of approximately 1 250 °C. The annular cooler has a grate bottom which permits cool air to penetrate the pellet layer. Walls divide the cooler into sections so as to provide hot air to the earlier process steps.

The overall process can be seen from Figure 4.

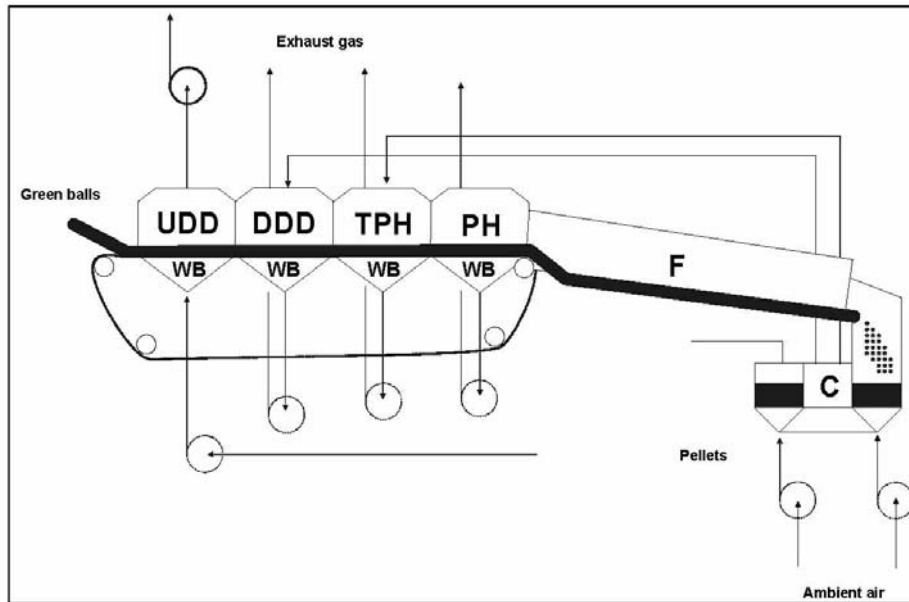

Figure 4. Schematic of the grate kiln process.

UDD	Up-draught drying with hot air from latter part of the cooler.
DDD	Down-draught drying with hot air from an intermediate part of the cooler.
TPH	Tempered preheated with hot air from an intermediate part of the cooler.
PH	preheating with hot waste gas from the rotary kiln.
F	Firing zone using hot air from first part of the cooler.
C	Cooling zone using cool (ambient) air.

When indurating magnetite, oxidation to hematite and sintering takes place in the TPH, PH, F and C section of the process (see Figure 3)

#### *Screening and Handling*

At the end of the induration strand, the pellets are collected and screened. Undersize or broken pellets can be recycled. Significant particulate matter emissions may occur.

For the stand-alone plants in Sweden, indurated pellets are kept in covered product bins before charging to open railway wagons for transport to the harbours at Narvik, Norway and Luleå, Sweden. In connection with ship loading 2-3 % of the material is screened off as undersize, which is sold as sinter feed. As for blast furnace material (coke, sinter, pellets, and lump ore) a final screening takes place at the blast furnace site.

#### **Present consumption/emission levels**

##### *Mass stream overview and input/output-data*

Figure 5 gives an overview of the input and output mass streams of a pelletisation plant. This overview may be used for the collection of data from single pelletisation plants.

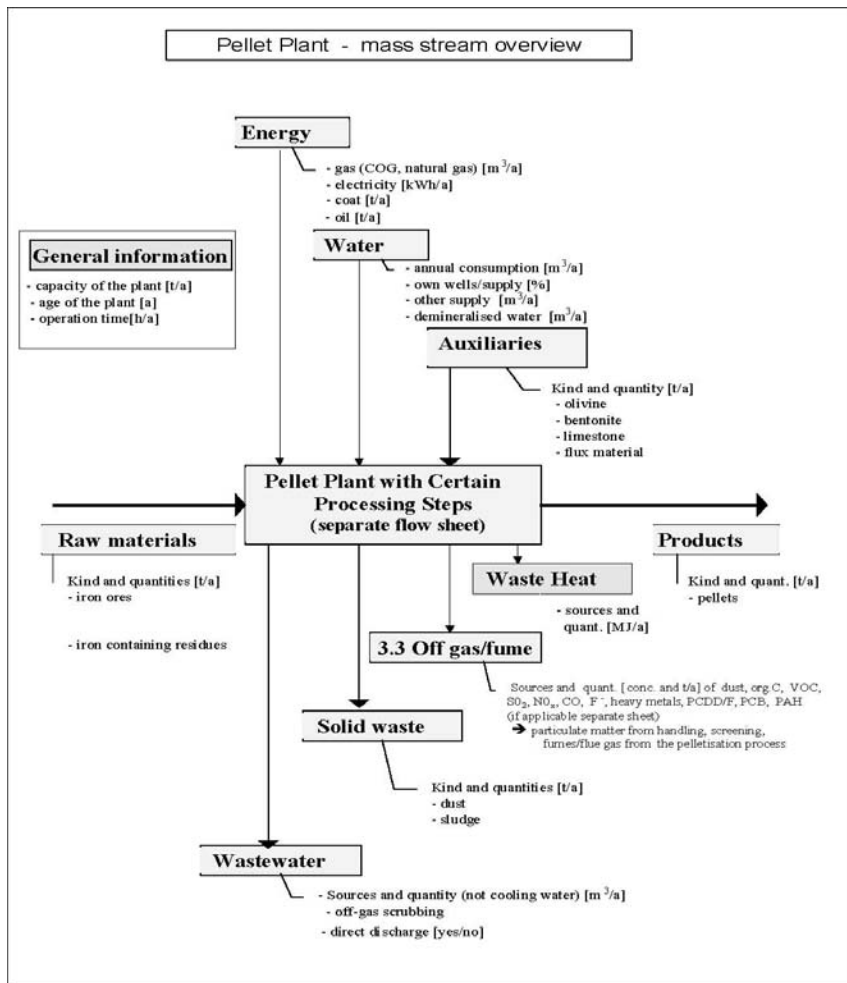

Figure 5. Mass stream overview of a pelletisation plant.

Subsequently, both specific input factors and emission factors can be calculated. Values of these factors at the five pelletisation plants in the EU are shown in Table 1. The emission factors are not referred to 1 t liquid steel like for sinter plants, coke oven plants and blast furnaces because the necessary conversion factors are not available. The specific waste gas flow is about 1940 to 2400 Nm<sup>3</sup>/t pellets.

Table 1. Input/output-data from the five pelletisation plant in the EU 15 data from 1996 to 1998 the emission data represent the emissions after abatement; information about the determination of the data like sampling methods, analysis methods, time intervals, computation methods and reference conditions is not available .

Input			Output		
Raw materials			Product		
iron ore	kg/t Pel	935 - 1120	pellets	kg/t Pel	1000.00
bentonite	kg/t Pel	5.1 - 7.2			
olivine	kg/t Pel	31 - 35.8	Emissions		
Limestone*1	kg/t Pel	0 - 3	dust	g/t Pel	20 - 130
dolomite*2	kg/t Pel	31	Cd	mg/t Pel	0.02 - 0.4
Quartzite*??	kg/t Pel	??	Cr	mg/t Pel	1 - 4.4
			Cu	mg/t Pel	1.7 - 7.5
			Hg	mg/t Pel	< 0.1 - 0.4
			Mn	mg/t Pel	8 - 38
Energy			Ni	mg/t Pel	5 - 25
COG*3	MJ/t Pel	398.7	Pb	mg/t Pel	3 - 130
natural gas*3	MJ/t Pel	209.0	Tl	mg/t Pel	n/a
coke*3	MJ/t Pel	283.0	V	mg/t Pel	21 - 150
Coal*4	MJ/t Pel	213 - 269	Zn	mg/t Pel	2.4 - 110
oil*4	MJ/t Pel	38 - 171	HF*5	g/t Pel	0.8 - 39
electricity	MJ/t Pel	51 - 128	HCl*5	g/t Pel	2 - 48
			S0x *6	g/t Pel	18 - 250
			N0x	g/t Pel	120 - 510
Water	m3/t Pel	0.11 - 1.5	CO	g/t Pel	<10*4 - 410
			CO2	kg/t Pel	15.6 - 31.8
			VOC*7	g/t Pel	< 5*4 - 40*3
Compressed air	Nm3/t Pel	6.2 - 15.2	PAH*8	mg/t Pel	0.19
			PCDD/F*4	µg I-TEQ/ t Pel	0.0057
			Residues/ by-products		
			Dusts	kg/t Pel	-

Legend: Pel = Pellets; n/a = not available

<sup>1</sup> in case of pellets production for direct reduction

<sup>2</sup> in case of pellets production for blast furnaces

<sup>3</sup> in case of the pelletisation plant is part of an integrated steelworks

<sup>4</sup> in case of stand-alone pelletisation plants in Sweden (magnetite ores)

<sup>5</sup> lower value if techniques for removal of acidic waste gas components are applied

<sup>6</sup> lower value if desulphurization techniques are applied

<sup>7</sup> measurement technique is not known

<sup>8</sup> information whether it is Borneff 6 or EPA 16 or benzo(a)pyrene is not available sum of EPA 16, calculated from Borneff 6 (EPA 16 = Borneff 6 x 4) with 2100 nm<sup>3</sup> / t sinter

## Ferrous metals processing industry (BREF II)

### Comments

- A closed water circulation system should be included as BAT technology at least in new cold rolling mills.
- In the burner technology happens a lot of further development both from the environmental impact and from the energy efficiency point of view.
- It is questionable if a technique from only one plant and from only one facility supplier can be considered as BAT as “Established techniques”.
- A new possible object for the list “Emerging techniques”.
  - Chromium-coating of the working rolls in the temper mill.
- In this chapter is also included
  - Castrip process update.

### Additional comments and notes

#### Hot forming-area

- S-content in fuel oil for reheating furnaces should be BAT for oil refineries. The SO<sub>2</sub>-content in the waste gas is BAT for reheating furnace technologies.
- Mandrelless coil-box is today “Established technique”, although it is in use only in a few existing plants.
- Ultra-low NO<sub>x</sub> -burner technology is coming to new reheating furnaces in the near future.

#### Cold forming-area

- Common notes.
  - There is a big lack of closer descriptions of different BAT-technologies.
  - Continuous pickling line is suitable only for longer production and product series.
- More detailed notices.
  - In the chapter II A.4.2.3 are presented several very common practices like
    - II A.4.2.3.5, Prevention of contamination.
    - II A.4.2.3.7, Cleaning and reuse of emulsion.
    - II A.4.2.3.8, Treatment of spent emulsion.
  - II A.4.2.5 The name should be Temper rolling instead of tempering.
    - Two different practices in temper rolling should be mentioned and described
      - Emulsion circulation-practice.
      - Emulsion non-circulation-practice.

### Hot dip galvanizing area

- II B.4.1.4.1, Low NO<sub>x</sub>-burners are today in common use. Ultra low NO<sub>x</sub>-burners are the next step.
- II B.4.1.5.1, Dross treatment (treatment of Zn-containing slag).
  - No reference plants in Europe !?, BAT?
- II B.6.1.4, Air knives with variable profile.
  - The technique is very difficult to manage, BAT ?!
- The update of the Castrip process for direct casting of thin (0.7-1.0) steel plates.

### Castrip process update

- Chapter A6 “Emerging techniques” for hot and cold forming.
- Pos. A6 1.4.2.
- Castrip process – twin roll strip casting process.
  - The castrip process is aimed at producing steel sheet between 0.7 and 2 mm in thickness utilizing twin roll strip casting technology. Commissioning of the world’s first commercial strip caster for low carbon steel production using castrip technology began in May 2002. The annual capacity of the plant is 500 000 t. The plant design is very compact.

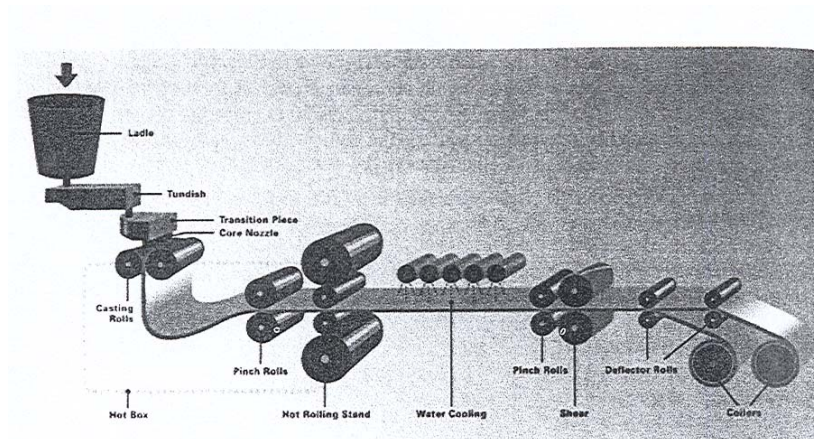

Figure 6. Castrip plant (presented by Rama Mahapatra at MEFOS’s conference SCANMET II, 6-9 June 2004, Luleå, Sweden)

The production volume in the first quarter of 2004 was 25 000 t and hourly production rates of 60 t/hr have been consistently achieved.

The product quality has shown to be suitable as a direct substitute for hot rolled coil as well as feed for cold rolling operations. The majority of strip thicknesses has been between 1.3 and 1.6 mm.

The strip casting technology has a good potential for a process of high energy efficiency and simultaneously of reduced environmental impact. These factors are mainly resulted by avoiding the hot rolling processes.

- Reference plant: Nucor Steel, Crawfordsville, Indiana.

Reference: The presentation at SCANMET II-conference, Luleå, June 2004.

# Presentation of BAT-examples from the Nordic Iron and Steel Industry

## Criteria for selection of objects

From the beginning of the project it was clear that in order to get a systematic way of working, it would be necessary to find out the criteria principles for selection of good Nordic examples. The criteria's used were as follows:

- When choosing the good examples of technologies and practice, we have used a Nordic base since the project is Nordic.
- The objects can be included in the existing BREF (2001), but they are used in an effective way with regards to environment and energy consumption. It can also be that the technology is used only in a limited number of plants.
- The object belongs to the existing BREF, but has a new application.
- A new object (is not included in the existing BREF), but the technology is applied in production.
- The object is included in the existing BREF, listed as “Emerging techniques”, but is today used in production in a Nordic reference plant.
- The object is under development and is listed as “Emerging techniques”.

The basis of these criterias was the content of the present BREF's.

It can be concluded that the criteria's were working well throughout the project. It was an important tool, both in own evaluations (project personnel) and in the discussions with the representatives in the industry. BAT definitions from the EU Commission also formed an important base for evaluations.

It is important to point out, that the presented list of objects is a selection from many BAT level techniques within the Nordic industry.

It is also worth mentioning, that several preliminary references have been left out at an early stage, because it was seen that they do not fully fulfil the criteria's for the objects of this project. This disqualification work was done in a good agreement between the contractor and representatives of the steering group.

## Presentation of the project description work, selection of the final objects

After the reference phase (short descriptions) the real descriptive work was carried out according to the IPPC-directive concept. The most essential point concerning BAT is the “**environmental impacts and benefits**”.

This point in the concept was added with “**energy efficiency**”, while the industry in question is energy intensive and in many cases environmental impact and energy efficiency have a high impact on each other!

Also “**productivity and product yield**” can influence the environmental impacts.

The most demanding part in the “Environmental impacts and benefits” was to work out sufficient and reliable data, not only verbal, but with figures. This was a real target in all the descriptions.

The descriptive work was carried out in co-operation with the representatives in the industry and a couple of objects were left out in this stage of the project. Simultaneously some new good objects (examples) were included into the project.

The selection criteria’s of the final objects with descriptions were the same as by selection of the objects at the reference state.

It was a lot of discussion inside the project and also between the Nordic BAT group and the actual project personnel, about the question, how many objects should be in the final list and should they be prioritized.

## References of the objects

The references of the objects are listed in the following way.

- I Objects in the BREF I, Production of iron and steel “Established techniques”
- I/E Objects in the BREF I, Production of iron and steel “**Emerging techniques**”
- II Objects in the BREF II, Ferrous metals processing industry “Established techniques”
- II/E Objects in the BREF II, Ferrous metals processing industry “**Emerging techniques**”

The objects have been numbered according to the process orders in the process steps and at the same time in accordance with the existing BREF’s as far as possible.

## Positioning of the objects

All of the selected objects in this document are positioned against the marking and positions in the corresponding BREF’s. The idea for this positioning is, that in the corresponding place in the present BREF, there are discussions and handling of the data for the same type of matters, or otherwise some connections with the object in question.

It is important to note that in some cases it was difficult to achieve accurate positioning.

*Objects in the BREF I – Production of Iron and Steel (Established techniques)*

**I/1 - Nordic practices for district heating**

- Ovako Hofors, practice
- Ruuki, Raahe Works, practice
- SSAB-Luleå practice

I/1.1

**Reference plant**

Ovako Hofors (+Hofors Energi), Sweden.

**Title of the object**

Using waste heat from the steel industry.

**Motivation**

Energy efficiency. A significant reduction of CO<sub>2</sub>-emissions.

**Practice**

On the list of “Established techniques”.

**Comment**

This object belongs to “Nordic practices for district heating”.

**Position in the present BREF**

Pos. I.9.2, EP 2.

I/1.2

**Reference plant**

Ruukki Production, Raahe Works, Iron and steelmaking, Finland.

**Title of the object**

Production of municipal district heating with steel works waste heat.

**Motivation**

Big influence in the overall energy efficiency and environment.

**Practice**

On the list of “Established techniques”.

**Comment**

The practice is working very reliable. This object belongs to Nordic practices for district heating.

**Position in the present BREF**

Pos. I.4.3.1, PI.2.

### I/1.3

**Reference plant**

SSAB Luleå Works, Sweden.

**Title of the object**

District heating in Luleå.

**Motivation**

Energy efficiency. Reduced CO<sub>2</sub>-emissions.

**Practice**

On the list of “Established techniques”.

**Comment**

A very high yield on energy. This object belongs to Nordic practices for district heating.

**Position in the present BREF**

Pos. I.7.3, Pl.2.

### I/2

**Reference plant**

LKAB, KK2 and KK3 in Kiruna, Sweden.

BUV in Malmberget, Sweden.

**Title of the object**

Low carbon dioxide emissions from magnetite based iron ore pellets productions.

**Motivation**

Significantly reduced CO<sub>2</sub>-emissions compared with hematite based pellets. High energy efficiency.

**Practice**

On the list of “Established techniques”.

**Comments**

LKAB is one of the world’s leading producers of BF-pellets and pellets for direct reduction with regard to environmental impact.

**Position in the present BREF**

Pos. I.5.2.

### I/3

**Reference plant**

LKAB, KK2 and KK3, Kiruna, Sweden.

**Title of the object**

Process-integrated NO<sub>x</sub>-abatement.

**Motivation**

Decreased NO<sub>x</sub>-emissions. Improved air quality.

**Practice**

On the list of “Established techniques”.

**Comments**

Low energy consumption is a supporting factor for NO<sub>x</sub>-abatement.

**Position in the present BREF**

Pos. I.5.3, PI.2.

**I/4 - Nordic blast furnace practice (BF-practice)**

The Nordic blast furnace practices are on the most advanced level in Europe (and in the world). This is valid for both the sinter operation in Raahe and the pellets operation in at the other three reference plants.

**Koverhar BF-practice, Finland**

- Small size, energy efficient blast furnace practice with 100 % pellets
  - Working volume approximately 600 m<sup>3</sup>.
  - The consumption of reducing agents 460-470 kg/ton HM.

**Blast furnace objects at Ovako Koverhar, Finland**

- Oxy-oil technology for the blast furnace.
- The use of models for controlling of the wear in the blast furnace hearth.

**Position in the present BREF**

Pos. I.7.

I/4.1

**Reference plant**

Ovako Koverhar, Finland.

**Title of the object**

Nordic blast furnace practice. Oxy-oil technology.

**Motivation**

Oil amount could be increased with approximately 100 %. Coke consumption and CO<sub>2</sub>-emissions are decreased.

**Practice**

On the list of “Established techniques”.

**Comment**

In production use for approximately five years. The development project was a co-operation between MEFOS, AGA and Koverhar.

**Position in the present BREF**

Pos. I.7.1.4.

I/4.2

**Reference plant**

Ruukki Production, Ovako Koverhar, Finland.

**Title of the object**

The use of models for controlling of the wear in the blast furnace hearth.

**Motivation**

Improved process control, improved iron quality. Improved energy efficiency and reduction of CO<sub>2</sub>-emissions.

**Practice**

On the list of “Established techniques”.

**Comment**

The models are developed in co-operation with the Finnish university, Åbo Academy.

**Position in the present BREF**

(I.7.1.)

**Raahe BF-practice, Finland**

“High productive, low reducing agents consumption practice”.

- Productivity 3.3-3.5 t/m<sup>3</sup>/day.
- Reducing agents consumption 450-460 kg/ton HM.

**Blast furnace objects at Ruukki Production, Raahe Works, Finland**

- Dry-quenching practice at coke production.
- Low slag volume blast furnace practice using sinter as raw material.
- Recovering heat from cowpers (hot stoves).

I/4.3

**Reference plant**

Ruukki production, Raahe Works, Iron and steelmaking.

**Title of the object**

Dry-quenching practice at coke production.

**Motivation**

Dry coke saves energy itself. Environmental impact by coke quenching. High availability (> 99 %).

**Practice**

On the list of “Established techniques”.

**Comment**

Coking is an own chapter in the BREF. This object belongs to the coke making area, but also into the Nordic BF-practice.

**Position in the present BREF**

Pos. I.6.3, PI.7.

I/4.4

**Reference plant**

Ruukki Production, Raahe Works, Iron and steelmaking, Finland.

**Title of the object**

Low slag volume Blast furnace practice using sinter as raw material.

**Motivation**

High productivity: 3.4 ton/m<sup>3</sup>/day. Reduced CO<sub>2</sub>-emissions by 15 kg/ton HM.

**Practice**

On the list of “Established techniques”.

**Comment**

The productivity represents the top level in Europe.

**Position in the present BREF**

Pos. I.7.1.

I/4.5

**Reference plant**

Ruukki Production, Raahe Works, Ironmaking, Finland.

**Title of the object**

Recovering of heat from cowpers.

**Motivation**

Energy efficiency. Reduced emissions: CO<sub>2</sub>, NO<sub>x</sub>, SO<sub>2</sub>.

**Practice**

On the list of “Established techniques”.

**Comment**

-

**Position in the present BREF**

Pos. I.7.3, PI.4, I.7.5.

**SSAB Oxelösund BF Practice, Sweden**

Energy efficient pellets based blast furnace practice with low slag volume and oxy-coal injection

**Blast furnace objects at SSAB, Oxelösund Works – Blast furnace No 2 and 4, Sweden**

- Oxy-coal-injection technique at the blast furnace.
- 100 % pellet-operation in the blast furnace.
- Low slag volume in the blast furnace (pellet practice).
- Briquettes – a way to be independent of a sinter plant to recycle in-plant fines.

I/4.6

**Reference plant**

Blast furnace No 4 at SSAB Oxelösund AB, Sweden.

**Title of the object**

Oxy-coal injection technique at the blast furnace.

**Motivation**

Reduced coke consumption. Improved combustion of the coal.

**Practice**

On the list of “Established techniques”.

**Comment**

The technique improved the whole BF-performance.

**Position in the present BREF**

Pos. I.7.1.4, I.7.5.

I/4.7

**Reference plant**

Blast furnace No 2 and 4 at SSAB Oxelösund AB, Sweden.

**Title of the object**

100 % pellets operation at the blast furnace.

**Motivation**

Reduced emissions to air. Total energy efficiency.

**Practice**

On the list of “Established techniques”.

**Comment**

-

**Position in the present BREF**

Pos. I.7.1.

I/4.8

**Reference plant**

Blast furnace No 2 and 4 at SSAB Oxelösund AB, Sweden.

**Title of the object**

Low slag volume using 100 % pellets.

**Motivation**

Decreased consumption of reducing agents. Reduced CO<sub>2</sub>-emissions.

**Practice**

On the list of “Established techniques”.

**Comment**

-

**Position in the present BREF**

Pos. I.7.1.

I/4.9

**Reference plant**

SSAB Oxelösund AB, SSAB Merox, Sweden.

**Title of the object**

Briquettes – a way to be independent of a sinter plant to recycle inplant fines.

**Motivation**

Environmental benefits – decreased deposits of landfill.

**Practice**

On the list of “Established techniques”.

**Comment**

-

**Position in the present BREF**

Pos. I.5.5.2.

**SSAB-Luleå, BF practice, Sweden**

High availability, low slag volume, energy efficient (coke and coal) BF-practice.

- Availability > 99 % (nearly 100 %).
- Slag volume 150-170 kg/ton HM.
- Reducing agents (coke and coal) at the level of 470 kg/ton HM.

**Blast furnace objects at SSAB, Luleå Works, Sweden**

- 100 % pellet operation in the blast furnace.
- Low slag volume in the blast furnace.
- Briquettes - a way to recycle in plant fines.

I/4.10

**Reference plant**

SSAB, Luleå Works, BF No. 3, Sweden.

**Title of the object**

100 % pellet operation.

**Motivation**

Decreased consumption of reducing agents. Reduced CO<sub>2</sub>-emissions.

**Practice**

On the list of “Established techniques”.

**Comment**

The blast furnace is well controlled. The BF is not very pressed in the production chain.

**Position in the present BREF**

Pos. I.7.1.

I/4.11

**Reference plant**

SSAB, Luleå Works, BF No. 3, Sweden.

**Title of the object**

Low slag volume using 100 % pellets.

**Motivation**

Reduction in CO<sub>2</sub>-emissions.

**Practice**

On the list of “Established techniques”.

**Comment**

\* A total impact on CO<sub>2</sub>-emissions is very significant taking into account both pellet producer and pellet user.

**Position in the present BREF**

Pos. I.7.1.

I/4.12

**Reference plant**

SSAB, Luleå Works, Sweden.

**Title of the object**

Briquettes - a way to recycle in plant fines.

**Motivation**

Decrease of deposits on landfill. Reduction in the main reducing agents (6-8 kg/ton HM reduction).

**Practice**

On the list of "Established techniques".

**Comment**

Avoidance of space and costs for landfill.

**Position in the present BREF**

Pos. I.5.5.2.

I/5

**Reference plant**

Ruukki Production, Raahe Works, Finland.

**Title of the object**

Utilization of iron making and steel making slags as products.

**Motivation**

A big potential of the CO<sub>2</sub>-emissions. The utilization of the slags is increasing.

**Practice**

On the list of "Established techniques".

**Comment**

A direct granulation of the BF-slag is in use.

**Position in the present BREF**

Pos. I.7.1.6.1.

**I/6**

**Reference plant**

Ruukki Production, Raahe Works, Iron and steelmaking, Finland.

**Title of the object**

The automatic ladle-lid system.

**Motivation**

Energy efficiency (improved temperature control). Less dust formation.

**Practice**

On the list of “Established techniques”.

**Comment**

Very good experiences!

**Position in the present BREF**

(Pos. I.8.1.)

**I/7**

**Reference plant**

SSAB Tunnpåt AB, Luleå Works, Sweden. Ruukki Production, Raahe Works, Finland.

**Title of the object**

Automated BOF-tapping practice.

**Motivation**

Increased productivity. Increased scrap-consumption, reduced CO<sub>2</sub>-emissions in the plant.

**Practice**

On the list of “Established techniques”.

**Comment**

The practices are quite similar at both reference plants.

**Position in the present BREF**

(Pos. I.8.1.)

**I/8**

**Reference plant**

SSAB Oxelösund AB, Sweden.

**Title of the object**

Continuous measurement of dust emissions from secondary dedusting system.

**Motivation**

The system allows a continuous control of the filter performance. A daily, weekly and monthly reporting of results happens. The BOF functions (charging, blowing, tapping) are very closely controlled.

**Practice**

On the list of “Established techniques”.

**Comment**

The system calibration according to the measured values happens once a year. The calibration period takes two days.

**Position in the present BREF**

Pos. I.8.2.2.1.1.3.

**I/9****Reference plant**

Ovako Koverhar, Finland.

**Title of the object**

Direct tapping from BOF.

**Motivation**

Increased energy efficiency. Positive environmental impact.

**Practice**

On the list of “Established techniques”.

**Comment**

Direct-tapping practice has been in use since 2001 for almost all steel grades.

**Position in the present BREF**

Pos. I.8.3, PI.3.

**I/10****Reference plant**

Ruukki Production, Raahe Works, Finland.

**Title of the object**

Efficient use of big amounts of scrap in converter process and efficient utilization of scrap arising at the works.

**Motivation**

High recycling rate of the scrap. A significant reduction of the CO<sub>2</sub>-emissions in the plant.

**Practice**

On the list of “Established techniques”.

**Comment**

The advanced scrap terminal practice is in use.

**Position in the present BREF**

Pos. I.9.1.1.

**I/11****Reference plant**

Ovako Imatra, Finland.

**Title of the object**

Filter plant service and monitoring system.

**Motivation**

It is of essential importance to keep the wastes on a low and constant level.

**Practice**

On the list of “Established techniques”.

**Comment**

Ovako Imatra has a very advanced control in this meaning.

**Position in the present BREF**

Pos. I.9.2.2.1.

**I/12****Reference plant**

AB Sandvik Materials Technology, Sandviken, Sweden.

**Title of the object**

Avoiding dust formation when emptying of slag pots.

**Motivation**

A lot of work and measurement have been done on this technology. The results are excellent from an environmental point of view.

**Practice**

On the list of “Established techniques”.

**Comment**

-

**Position in the present BREF**

Pos. I.9.1.7.

**I/13****Reference plant**

AB Sandvik Materials Technology, Sandviken, Sweden.

**Title of the object**

Determination of some environmental sensitive elements in waste water.

**Motivation**

Quick and efficient technique using standard equipment.

**Practice**

On the list of “Established techniques”.

**Comment**

-

**Position in the present BREF**

Pos. I.9.2.2.3.

**I/14****Reference plant**

SSAB Tunnbrått AB, Luleå (Oxelösund), Sweden.

**Title of the object**

Biological waste water treatment at coking plant.

**Motivation**

Effective reduction of TOC in process water.

**Practice**

On the list of “Established techniques”.

**Comment**

TOC = Total organic carbon.

**Position in the present BREF**

I.6.3, EP11.

*Objects in the BREF I – Production of Iron and Steel (Emerging techniques)*

**I/1E****Reference plant**

SSAB Oxelösund AB, Sweden.

**Title of the object**

Frequency-converted control of pumps and fans for circulative cooling and cleaning water, and for off-gas suction system at the LD-process.

**Motivation**

The system allows significant improvement in the total energy efficiency of the BOF.

**Practice**

On the list of "Emerging techniques".

**Comment**

The system is partly already in use. The whole utilisation of this practice is going to happen during the year 2005.

**Position in the present BREF**

Pos. I.8.5., I.8.2.2.4.

**I/2E****Reference plant**

Ovako Koverhar, Finland.

**Title of the object**

Burning and recycling of the dry waste dusts (Radust process), pilot plant.

**Motivation**

The technology has a remarkable environmental impact.

**Practice**

On the list of "Emerging techniques".

**Comment**

The pilot plant is running. The size of the plant covers is in principle the needs of Koverhar dusts.

**Position in the present BREF**

Pos. I.8.5.

**I/3E****Reference plant**

Outokumpu Stainless, Tornio Works, Finland.

**Title of the object**

Production stainless steel slag products.

**Motivation**

Utilization of stainless steel slag products. Decreasing significantly the amount of wastes. Decreasing dusting at the dumping station and slag yard.

**Practice**

On the list of “Emerging techniques” and “Established techniques”.

**Comment**

Requires some further investment.

**Position in the present BREF**

Pos. I.9.5, I.9.1.7.

*Objects in the BREF II – Ferrous metals processing industry (Established techniques)*

**II/1****Reference plant**

Ovako Imatra, Finland.

**Title of the object**

Hot charging of blooms into the reheating furnace.

**Motivation**

A significant impact on the environment and on energy efficiency.

**Practice**

On the list of “Established techniques”.

**Comment**

The figures for hot charging is especially high for Ovako Imatra’s demanding product mix, = > 90 %.

**Position in the present BREF**

Pos. II.A.4.1.3.17.

**II/2****Reference plant**

Ruukki Production, Fundia Mo Works, Hot rolling mill, Norway

**Title of the object**

Environmentally sound and energy efficient reheating of steel billets in a mini-mill reheating furnace.

**Motivation**

Environmental impact. Energy efficiency.

**Practice**

On the list of “Established techniques”.

**Comment**

In the reheating furnace oil, CO and H<sub>2</sub>-gas is used.

**Position in the present BREF**

II.A.3.1.3.

**II/3****Reference plant**

Ruukki Production, Raahe Works, Finland.

**Title of the object**

Mandrelless coilbox.

**Motivation**

Reduced energy consumption. Improved product yield. Reduction of emissions.

**Practice**

On the list of “Established techniques”.

**Comment**

This technique is in use only in a few European works.

**Position in the present BREF**

Pos. II.A.4.1.7.1.

**II/4****Reference plant**

Outokumpu Avesta Works, Sweden.

**Title of the object**

Oxy-fuel technology for heating operations.

**Motivation**

Increased energy efficiency by 40-50 % compared with conventional burners. Reduced NO<sub>x</sub>-emissions. Increased productivity.

**Practice**

On the list of “Established techniques”.

**Comment**

There are several applications of this practice at Outokumpu Works.

**Position in the present BREF**

Pos. II.A.4.1.3.6.

## **II/5**

### **Reference plant**

Ruukki Production, Hämeenlinna Works, Finland.

### **Title of the object**

Turbulence-pickling for the continuous pickling line for carbon steel.

### **Motivation**

High efficiency and productivity. A clear environmental impact, while the HCC-emissions into the air have been reduced by approximately 90 %.

### **Practice**

On the list of “Established techniques”.

### **Comment**

This technology is in use in approximately 10 % of the European plants.

### **Position in the present BREF**

Pos. II.A.4.2.2.5.

## **II/6**

### **Reference plant**

Outokumpu Stainless (Coil Products, Nyby, Avesta Works, Hot rolled plate, Degerfors).

### **Title of the object**

Increased productivity through turbulent pickling.

### **Motivation**

Reduction of acid consumption. Reduction of wastes. Increased productivity.

### **Practice**

On the list of “Established techniques”.

### **Comment**

Three process applications in use.

### **Position in the present BREF**

Pos. II.A.3.2.2.

## **II/7**

### **Reference plant**

Outokumpu, Tornio Works, Finland.

### **Title of the object**

SCR-technology. For NO<sub>x</sub>-reduction in the pickling line.

**Motivation**

A high reduction efficiency, = up to 95 %. One of the highest in Europe.

**Practice**

On the list of “Established techniques”.

**Comment**

SCR = Selective Catalytic Reduction.

**Position in the present BREF**

Pos. II.A.4.2.2.21, II.D.2.4.

**II/8****Reference plant**

Outokumpu Stainless, Coil Products Nyby, Torshälla, Sweden.

**Title of the object**

NO<sub>x</sub>-suppression by injection of hydrogen peroxide (H<sub>2</sub>O<sub>2</sub>).

**Motivation**

NO<sub>x</sub>-reduction by 70-90 % from the pickling acids. Reduction in acid consumption.

**Practice**

On the list of “Established techniques”.

**Comment**

Availability for smaller pickling units. Investment costs lower compared to catalytic systems.

**Position in the present BREF**

Pos. II.A.4.2.2.20, II.D.5.8.1.

**II/9****Reference plant**

Outokumpu, Tornio Works, Cold rolling, Finland.

**Title of the object**

OSAR-practice - Outokumpu Sulfurdioxide Aided chromium Reduction. .

**Motivation**

This practice is the most effective reduction process for Cr<sup>+6</sup> in the stainless steel pickling line.

**Practice**

On the list of “Emerging techniques”.

**Comment**

-

**Position in the present BREF**

(Pos. II.A.3.2.2.)

**II/10****Reference plant**

Outokumpu, Tornio Works, Finland.

**Title of the object**

OPAR - Outokumpu Pickling Acid Recovery system.

**Motivation**

A very advanced technology. Both metals and acids are recovered.

**Practice**

On the list of “Emerging techniques”.

**Comment**

-

**Position in the present BREF**

Pos. II.A.3.2.3.

**II/11****Reference plant**

Outokumpu Stainless, Coil Products, Nyby Torshälla, Sweden.

**Title of the object**

Acid recycling by electrodialysis.

**Motivation**

Reduction of fresh acid consumption. Reduction of waste products to be deposited on landfill.

**Practice**

On the list of “Emerging techniques”.

**Comment**

Good results from the reference unit.

**Position in the present BREF**

Pos. II.A.4.2.2.1.

## **II/12 - Nordic Hot dip (batch) galvanizing**

II/12.1

### **Reference plant**

JIWE Varmförzinkning AB, Sölvesborg, Sweden.

### **Title of the object**

Hot dip galvanizing at JIWE.

### **Motivation**

Minimized environmental impacts.

### **Practice**

On the list of “Established techniques”.

### **Comment**

Clean working conditions.

### **Position in the present BREF**

Pos. II.C.3.

II/12.2

### **Reference plant**

Dansk Overflade Teknik AS (DOT), Koge, Danmark.

### **Title of the object**

The pre-treatment process at hot dip galvanizing.

### **Motivation**

Clean technology. Low environmental impacts.

### **Practice**

On the list of “Established techniques”.

### **Comment**

The pre-treatment takes place under constant conditions.

### **Position in the present BREF**

Pos. II.C.4.2.4, II.C.4.3.3.

II/12.3

### **Reference plant**

Ørsta Stål As, Norway.

**Title of the object**

Powder coating of hot dip galvanized (HDG) steel product.

**Motivation**

Powder coating is an energy efficient and environmentally friendly alternative to provide zinc coating with added protection.

**Practice**

On the list of “Established techniques”.

**Comment**

-

**Position in the present BREF**

Pos. II.C.2.10.

II/12.4

**Reference plant**

Galvanoimis Oy, Finland.

**Title of the object**

Filtration of gases/fumes from hot dip galvanizing bath.

**Motivation**

Low emission level after bag filter. High energy efficiency.

**Practice**

On the list of “Established techniques”.

**Comment**

Improved working conditions.

**Position in the present BREF**

Pos. II.C.4.6.

II/13

**Reference plant**

Ruukki Production, Hämeenlinna Works, Finland.

**Title of the object**

Roll coater in the passivation of the hot dip galvanized strip.

**Motivation**

The passivation will be done for the Zn-coated strip plates. With help from the roll coaters, the amount of Zn into the passivation solution is reduced by approximately 90 % compared with the traditional practices.

**Practice**

On the list of “Established techniques”.

**Comment**

The roll-coater practice has been in use since the year 2000. This technology is in the 2001 BREF document on the list of “Emerging techniques”.

**Position in the present BREF**

Pos. II.B.6.1.1.

*Objects in the BREF II – Ferrous metals processing industry (Emerging techniques)*

**II/1E****Reference plant**

Ovako Dalsbruk, Finland.

**Title of the object**

Endless rolling practice for demanding wire-rod products.

**Motivation**

Possibility to high efficiency (productivity) and high-yield technology. A significant customer advantage = optimum coil weight.

**Practice**

On the list of “Emerging techniques”.

**Comment**

-

**Position in the present BREF**

Pos. II.A.6.1.4.1.

**II/2E****Reference plant**

Ruukki Production, Raahe Works, Hot rolling mill, Finland.

**Title of the object**

Sequential impulse firing burner technology in the reheating furnace in the hot strip mill.

**Motivation**

Time-based control of burners functioning with nominal gas flows. Optimal heat input in every production condition with good energy efficiency and reduced emissions.

**Practice**

On the list of “Emerging techniques”.

**Comment**

This technology will be taken into use in connection with the new reheating furnace in April 2005.

**Position in the present BREF**

Pos. II.A.6, A.4.1.3.2.

**II/3E****Reference plant**

Outokumpu, Avesta Works, Sweden.

**Title of the object**

Processing of hydroxide sludge from stainless steel pickling to a usable slag former in the melting shop.

**Motivation**

High efficiency and high productivity. Recycling of hydroxide sludge gives a high environmental standard.

**Practice**

On the list of “Emerging techniques”.

**Comment**

The hydroxide sludge is transformed to “hydroflux” that is used as fluxing agent instead of fluorspar in the steel converter.

**Position in the present BREF**

Pos. II.A.6, II.A.4.2.

**II/4E****Reference plant**

Ruukki Production, Hämeenlinna Works, Finland.

**Title of the object**

Passivation with Cr+6-free products in the continuous hot dip galvanizing line.

**Motivation**

A very important environmental impact.

**Practice**

On the list of “Emerging techniques”.

**Comment**

Some full-scale (production-scale) trials have been done. In the year 2007, the truck industry does not accept the use of Cr<sup>+6</sup>.

**Position in the present BREF**

Pos. II.B.6.1.3.

**II/5E**

**Reference plant**

SSAB Tunnpååt AB, Borlänge, cold rolling mill, Sweden.

**Title of the object**

Advanced SCR-application for NO<sub>x</sub>, reduction in annealing line.

**Motivation**

Reduction of NO<sub>x</sub>. The reduction rate is 75 % at the present.

**Practice**

On the list of “Emerging techniques”.

**Comment**

This technology is in operation since one year at a continuous annealing line with very fast changes of the waste gas flow.

**Position in the present BREF**

Pos. II.D.2.4.

## Descriptions of the objects

*Objects in the BREF I – Iron and steel production (Established techniques)*

### **I/1 - Nordic practices for district heating**

#### I/1.1

#### **Using waste heat from the steel industry**

##### *Description of the techniques*

Steam for the manufacturing processes at OVAKO Hofors is generated primarily through the combustion of wood chips.

Several different technical solutions are employed to utilise waste heat from the steel industry's processes. Some of the technology is newly developed.

Where steel needs to be cooled both heat pumps and solar panels are used.

Flue gas boilers are used in furnaces with high temperatures, while oxygen evaporation and compressor cooling are used to exchange energy across standard heat exchangers.

The energy that is recovered is distributed either through the district heating network or to other parts of OVAKO Hofors's plant and the entire centre of the Hofors community.

##### *Applicability*

The method is used primarily in all steel works that use similar cooling technology.

##### *Environmental impact and benefits, energy efficiency*

Hofors Energi AB delivers a total of around 130 GWh per annum to OVAKO Hofors and the Hofors community. A third of this is in the form of steam whereas the rest is in the form of hot water.

By generating steam with the help of biofuels, oil consumption at OVAKO Hofors is reduced by approximately 4 000 m<sup>3</sup> per annum.

Making use of waste heat means savings of up to a further 4 000 m<sup>3</sup> per annum. In total this means a reduction in CO<sub>2</sub> emissions of 23 000 tonnes per annum for OVAKO Hofors.

As a result of the collaboration between OVAKO Hofors and Hofors Energi AB, the community of Hofors is supplied with district heating, which reduces oil consumption in buildings by a further 4 000 m<sup>3</sup> of oil per annum. This means a reduction in CO<sub>2</sub> emissions of approximately 11 000 tonnes per annum.

##### *Cross-media effects*

The use of biofuel means that OVAKO Hofors can benefit from its allocated emission quota for CO<sub>2</sub> directly in its processes without having to take premises heating etc. into account.

##### *Driving force for implementation*

Environmental benefits, reduction of CO<sub>2</sub> emissions.

### *Economics*

Income from selling waste heat.

### *Reference plant*

OVAKO Hofors, Sweden.

### *Position in the present BREF*

I.4.3.1, P12.

## I/1.2

### **Production of municipal district heating with steel works waste heat**

#### *Description of the techniques*

In the municipal district heating system thermal energy is delivered with the help of the closed piping for the heating of the buildings and of other premises and for the production of warm service water. The consumer always receives the heat with the help of heat exchangers. Each of the buildings has similar connections for example for electrical net, for gas net, for clean water and waste water nets.

The district heating systems are utilized quite general on the city areas of the Nordic countries and Russian but nowadays quite general also in small communities. The heat is produced in big towns in big power plants with combined electricity and heat production (CHP). In small communities the heat is produced with separate boiler plants burning fixed fuels, heavy oil or natural gas.

The temperature of the district heating water is adjusted according to open air in the range of 75-120 °C. The temperature of returning water will be around the year 40-45 °C. Causing of the low temperature in the district heating system there are many possibilities to produce district heat in the steel works and to utilize waste heat of process coolings.

A significant advantage in the district heating system is the cleanness of circulating water and a big temperature difference in the circulating water. Therefore it can be possible to connect the production of the heat and the specific cooling solutions of processes so as the system has realized by Rautaruukki. In cooling solutions of processes in which district heating can be produced, extremely good energy efficiency (transferred heat/used electricity) and economy will be achieved.

One specific feature in the industrial district heating solution is connected to the optimisation and to the controlling. When about 90 % of annual heat demand is produced with waste heat of many processes, it should be quite complicated continuously to divide optimal the heat loads and to control temperatures and pressures in the other producing points.

Otherwise the technology is quite simple and it belongs to the list "Established techniques".

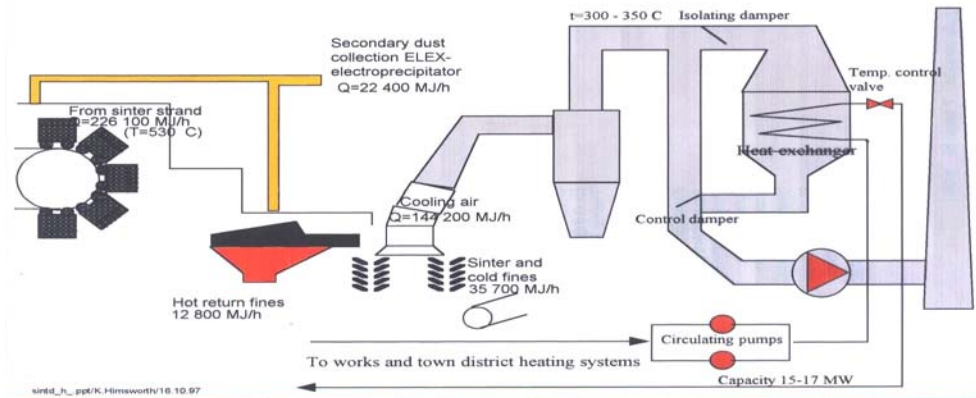

Figure 7. Sinter plant district heating system

### *Applicability*

In normally the industry premises of steel works, offices and service rooms have mainly been connected to the own district heating network of the works. The neighbouring town possibly has own district heating network. For example in the town of Raahe of about 25 000 inhabitant has been begun a district heating operation in the 1970's. The district heating networks of the steel works and of the town of Raahe have been connected in the year 1981, when the delivering of the heat is started.

The practice is applicable in every small or big towns, where district heating net is already situated or heating much enough is needed.

### *Environmental impacts and benefits, energy efficiency*

The municipal district heating is delivered to Raahen Energia the 160 000 MWh/a with which the use of heavy fuel oil is replaced about 18 000 t/a. A similar amount of energy is replaced with Raahe Steel Works internal fuels, vapour and electricity which would be used for the production of the heat without the district heating system and without the waste heat utilizing.

Moreover the energy consumption in the steel works is reduced when it has been possible to sell waste heat to Raahen Energia.

### *Cross-media effects*

The district heating is a safe, economically and carefree heating method for the customer and it can increase the price of houses and the status of living area.

### *Driving force for implementation*

Energy saving with the Raahe Steel Works and reduced environmental impacts in the town of Raahe.

### *Economics*

The construction of the district heating system succeeds quite advantageous and utilizing the technology that has been generally used. For this reason the system has been an extremely profitable sector to Raahe Steel Works and moreover there are extremely advantageous district heating tariffs in the town of Raahe for the end user. To the area of Raahe has been obtained new industry using district heat.

*Reference plant*

Ruukki production Raahe Steel Works and the town of Raahe, Finland.

*Position in the present BREF*

I.4.3.1, P1.2.

I/1.3

**District Heating Luleå**

*Description of the techniques (see Figure 8 below)*

In the metallurgical units coal is used as a chemical reactant to extract iron from ore. Energy rich gases are recovered as a by-product. One part of these gases is recirculated to cover internal needs. The rest is used in the local CHP (Combined Heat and Power plant) to produce heat and electrical power.

In 2004 the total energy delivery from the system was:

**Fuel input**

Gas	2075 GWh
Oil	82 GWh
Energy output	
Total energy export	1472 GWh
Hot water to District heating	751 GWh
Electric power export	613 GWh
Steam export	27 GWh
Drying gas export	81 GWh

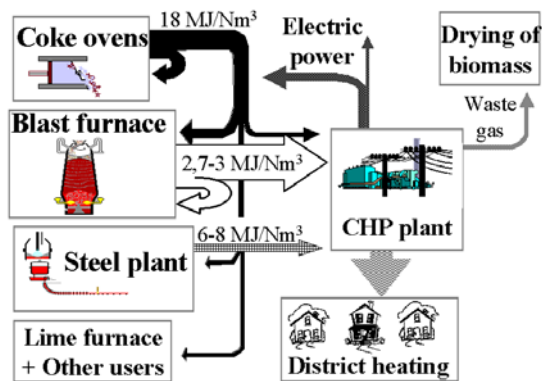

Figure 8. Energy gas flowsheet (from ref).

For further data see ref.

*Applicability*

This method is applicable for all cities close to integrated steel plants. The same appears for many other process industries.

The main restrictions against application are political/ legal. E.g. already recovered energy that could heat a neighbour community is not used and is instead created by incineration of waste. Economic support makes this practice profitable.

*Environmental impact and benefits, energy efficiency*

From the start to end 2003, 12 995 GWh of hot water was delivered to local district heating. Approximately 4.5 Mtonnes of CO<sub>2</sub> would have been produced if the same amount of heat had generated using heavy fuel oil (assuming a recovery of 90 % and a specific CO<sub>2</sub> value of 0.0879 tonne CO<sub>2</sub>/GJ). Using the same conditions, the amount of NO<sub>x</sub> and SO<sub>x</sub> avoided could be calculated to approximately 1 800 and 600 tonnes, respectively, se ref.

The electrical power covers the need of SSAB Tunnplåt AB and also gives some surplus which can be used elsewhere. The heat production covers the total need of district heating in Luleå (22 000 Homes).

Also a local biomass plant uses surplus energy from the system. For further data see ref.

#### *Cross-media effects*

By-product energy gases from the Steel plant are converted into electric power and hot water from district heating. The combined production of power and heat gives a very high yield on energy (68 % for the data given above). The limitation for further increase is the ability of the surrounding system to absorb more hot water energy

#### *Driving force for and against implementation*

The driving forces for implementation are environmental benefits, improved BF operation and avoidance of high investment costs.

As mentioned above the driving forces against implementation are mainly of legal or political nature. This also decreases the driving force for recovering surplus energy from other sources in the plant. The system of "Green Certificates" could give extra costs if that energy is further developed into electricity.

#### *Reference plant*

Total system SSAB-Lulekraft-District Heating in Luleå.

#### *References*

Grip C E and Thorsell A, "Swedish national research program for energy saving by means of process integration", 2nd International conference on Process development in Iron and Steelmaking (SCANMET II), 6-9 June 2004, Luleå, Sweden.

Petrini H et al, "Energy network SSAB - LULEKRAFT - City of Luleå: two decades' experience of co-production of steel, electric power and district heating", 2nd International conference on Process development in Iron and Steelmaking (SCANMET II), 6-9 June 2004, Luleå, Sweden.

#### *Position in the present BREF*

Pos. I.7.3, P1.2.

## **I/2**

### **Low carbon dioxide emissions from magnetite based iron ore pellets production**

#### *Descriptions of the techniques*

The greenhouse gas carbon dioxide emissions in the pelletizing process originates from the use of fossil fuels (65-75 %), carbonate additives (25-35 %), and organic additives (< 1 %).

Oil and coal are used in the magnetite based grate kiln process, while only oil is used in the straight grate process. These fossil fuels are used for the extra energy demand in the sintering of magnetite green pellets magnetite to hematite pellets. The oxidation process is exothermic and corresponds to ca. 60 % of the total energy demand. Small input of external energy guarantees low specific carbon dioxide emissions.

Pelletisation of hematite concentrate is approximately consumes approximately 60 % more energy compared with magnetite ore since there is no exothermic reaction taking place during the pelletisation.

#### *Applicability*

The use of magnetite pellet feed in the pelletizing process together with a very energy efficient process will enhance an overall carbon dioxide performance of the steel production chain.

#### *Environmental impacts and benefits*

Anthropogenic carbon dioxide emission constitute approximately of 4 % of total carbon dioxide emission. The Kyoto agreement requires reduced carbon dioxide emission. Steel production is energy intensive with the result of carbon dioxide emission. The carbon dioxide emission at the LKAB pelletizing plants is approximately 20 kg CO<sub>2</sub>/ton blast furnace pellets.

Every ton of steel produced from magnetite based pellets, however, will decrease the carbon dioxide emission to 30 % compared with hematite based pellets. It is, therefore, important to increase the production at Malmberget and Kiruna, where the ores are primarily magnetite.

#### *Cross-media effects*

An energy efficient pelletizing process will also decrease the emission of sulphur dioxide and nitrogen oxides. The sulphur dioxide emission was reduced with approximately more than 95 % at LKAB Kiruna pellet plant in 1995 due to the installation of scrubbers. The emission is approximately 13 grams/ton pellets. The source of sulphur is primarily from the coal and oil fuel. A more energy efficient system will, therefore, result in further reduced sulphur dioxide emission.

NO<sub>x</sub> emissions range from 150 gram/ton pellets and 260 gram/ton product. The sources of NO<sub>x</sub> emission are nitrogen in the air and in the fuel. Efficiency improvement in the energy system will, therefore, reduce the NO<sub>x</sub>. This is further discussed in section 2.2.1.

#### *Driving force for implementation*

Better environmental performance in plant.

The national allocation plans in the European carbon dioxide trading system

#### *Economics*

-

#### *Reference plant*

LKAB pelletizing plants KK2, KK3 in Kiruna and BUV in Malmberget, Sweden.

#### *Position in the present BREF*

Pos. I.5.2.

I/3

## **Process-integrated NO<sub>x</sub> abatement**

### *Descriptions of the techniques*

The most important measures that can be taken to reduce overall NO<sub>x</sub> emissions from the pelletisation plant aim at reducing formation of thermal NO<sub>x</sub>. This can be achieved by lowering the (peak) temperature in the burners and reduction of the oxygen excess in the combustion air.

The main factors for thermal NO<sub>x</sub> formation are the high temperatures (1300-1400 °C) and the high availability of oxygen in the burner zone. NO<sub>x</sub> that is formed in the pellet bed mainly consists of “prompt- NO<sub>x</sub>” and “fuel- NO<sub>x</sub>”, which are formed by reactions between fuel and oxygen and nitrogen in the air. It is not possible to distinguish between the various forms of NO<sub>x</sub> after they have formed, there being no difference in chemical composition.

At the KK3 pelletisation plant of the company LKAB, Kiruna, Sweden, NO<sub>x</sub> emissions from the firing zone are 175 g/t pellet. The low NO<sub>x</sub> emissions were achieved by a combination of low energy use, low nitrogen content in the fuel (coal and oil) and limiting the oxygen excess.

At the KK2 pelletizing plant of the company LKAB, Kiruna, Sweden, indirect coal firing technique is used is recently implemented instead of direct coal burning. The NO<sub>x</sub> emissions from this plant are 150 g/t pellet. The “Indirect coal” means that the coal is milled, filtered and is stored before it is used in the burner. The technique makes it possible to fine adjust energy use and the amount of transport air is small which means that one of the requirements for the formation of thermal NO<sub>x</sub> is minimised.

### *Applicability*

The use of magnetite pellet feed in the pelletizing process together with a very energy efficient process will enhance an overall NO<sub>x</sub> performance of the steel production chain.

“Grate kiln” pelletizing processes.

### *Environmental impacts and benefits*

Decreased NO<sub>x</sub> emissions influence the acid and fertilising deposition of nitrogen compounds in the surroundings of the plant. The air quality can also be improved

### *Cross-media effects*

As discussed above.

### *Driving force for implementation*

The driving forces for implementation of air emission improvement are national and international regulations (air emission standards for NO<sub>x</sub>) and the European emission trading system, environmental reputation and improved economics.

### *Economics*

-

### *Reference plant*

KK2 and KK3, LKAB Kiruna, Sweden.

*Position in the present BREF*

Pos. I.5.3, P1.2.

#### **I/4 - Nordic Blast furnace practice**

The Nordic blast furnace practices are on the most advanced level in Europe (and in the world). This is valid for both the sinter operation in Raahe and the pellets operation at the other three reference plants.

#### **Koverhar BF-practice, Finland**

- Small size, energy efficient blast furnace practice with 100 % pellets.
  - Working volume approximately 600 m<sup>3</sup>.
  - The consumption of reducing agents 460-470 kg/ton HM. (Hot Metal)

#### **Blast furnace objects at Ovako Koverhar, Finland**

- Oxy-oil technology for the blast furnace.
- The use of models for controlling of the wear in the blast furnace hearth.

I/4.1

#### **Oxy-oil -technology**

##### *Description of the techniques*

The main equipment consists of oxy-oil –burners, which are installed to all tuyeres, and which are specially planned for this purpose.

In the burners there are the feeders separately for oil and oxygen and the burning happens as complete and effective as possible.

The equipment is developed in co-work with the experts are Ruukki Production/ Ovako Koverhar and Raahe Steel Works, AGA AB and MEFOS. In full scale use the practice has been since 2000.

The amount of oil is at present 130 kg/ton HM. The oil is extra heavy fuel oil where the temperature must be 200-220 °C. This kind of oil should have very little use for other purposes.

The amount of oxygen enrichment is at present 7-9 %-units.

This oxy-oil –practice belongs to “Established techniques”.

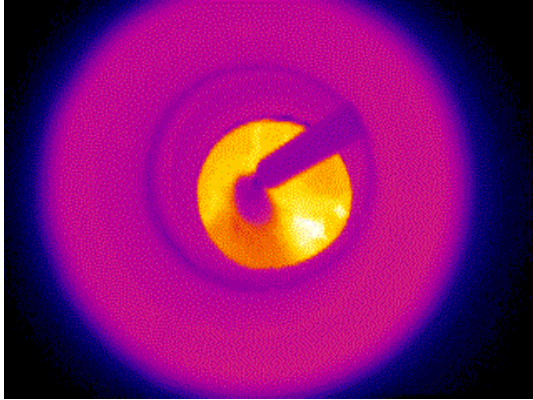

Figure 9. Oxy-oil lance in tuyere

#### *Applicability*

The equipment and the practice are working very reliably. The applicability of the equipment for feeding of oil and oxygen is good.

#### *Environmental impacts and benefits, energy efficiency*

The oil consists of carbon and hydrogen and it compensates coke with a ratio of 1:1.2 (1 kg oil compensates also 1.2 kg coke). With the help of the oxy-oil-equipment the oil amount is doubled to a level of 130 kg/ton HM. The saving of coke is thus about 15 kg/ton HM and the reduction in CO<sub>2</sub>-emissions roughly 50 kg/ton HM. The environmental benefit and the energy efficiency are thus significant.

#### *Cross-media effects*

A problematic product (extra heavy fuel oil) will in this practice be effectively utilized.

#### *Driving force for implementation*

Cost savings, productivity and reduced CO<sub>2</sub>-emissions.

#### *Economics*

-

#### *Reference plant*

Ovako Koverhar, Finland.

#### *Position in the present BREF*

Pos. I.7.1.4.

## I/4.2

### **The use of models for controlling of the wear in the blast furnace hearth**

#### *Description of the techniques*

There are two separate methods in use:

- a. A model, which is estimating the location of the 1150 °C isotherm based on thermal conductivities and thermocouple measurements in the hearth refractory lining by using FEM-method (Finita Element Method).

- b. A model, which approximates the height of the “dead man” in the hearth according to the thermal conductivity.

The models are of significant importance for the control of the blast furnace –process and for the wear in the BF-hearth. Also the quality of the BF-iron can be held on good and constant level (exp. C- and Si- and S-contents), when the phenomena in the hearth can be controlled.

#### *Applicability*

The methods are applicable both for new and existing blast furnaces.

#### *Environmental impacts and benefits, energy efficiency*

The consumption of reducing agents are reduced approximately with 5 kg/ton HM on a long term basis. This means a reduction of CO<sub>2</sub>-emissions by approximately 15-20 kg/ton HM. The BF-campaign life can be prolonged by several years.

#### *Cross-media effects*

Reduction in refractory-consumption.

#### *Driving force for implementation*

- A significant improvement in the control of the BF-hearth.
- Positive impacts on the energy efficiency and on the environment.

#### *Economics*

A clearly positive impact.

#### *Reference plant*

Ovako Koverhar, Finland.

#### *Position in the present BREF*

(Pos. I.7.1.)

### **Raahe BF-practice, Finland**

“High productive, low reducing agents consumption practice”.

- Productivity 3.3-3.5 t/m<sup>3</sup>/day.
- Reducing agents consumption 450-460 kg/ton HM.

### **Blast furnace objects at Ruukki Production, Raahe Works, Finland**

- Dry-quenching practice at coke production.
- Low slag volume blast furnace practice using sinter as raw material.
- Recovering heat from cowpers (hot stoves).

#### I/4.3

### **Dry quenching practice at coke production**

#### *Description of the techniques*

The coke dry quenching (CDQ) plant consists of three dry quenching chambers and their associated waste heat boilers and charging cranes as three combined units. Coke is cooled in these chambers by means of circulation gas. The circulation gas is a mixture consisting mainly of nitrogen and other inert gases. This mixture is formed when the oxygen burns out during the start-up stage of the cycle. The temperature of the circulation gas after the chamber is about 780 °C and after the boiler about 150 °C.

The temperature of the coke charged to the dry quenching chamber is about 1050 °C and after the chamber about 180 °C. Coke flows through the chamber in about 5 hours and the flow rate of circulation gas is about 75 000 Nm<sup>3</sup>/h.

The nominal capacity of the current dry quenching plant is 150 t/h (50 t/h/chamber). Actual coke production is about 105 t/h, so the capacity of two chambers is not quite enough for handling of all coke. As a result of this the dry quenching plant is operated in such a way that two chambers and boilers work with full capacity and one is charged with about 10 % of the coke production. This reduced capacity unit is so called warm reserve. A unit working at full capacity produces about 25 t/h of high-pressure steam (93 bar) and a unit as warm reserve about 2,5 t/h of low-pressure steam (8 bar).

Coke is transported with belt conveyors from the CDQ- plant to the blast furnace coke screening station.

Coke with grain size over 8mm is used in the blast furnace in two fractions and under 8 mm fractions are used mainly as fuel in the sinter plant.

#### *Applicability*

The moisture content of coke is approximately 0.05 % compared to that of wet quenched coke which is approximately 2-5 %. Therefore coke is more applicable and its quality is more uniform for blast furnace operation.

#### *Environmental impact and benefits, energy efficiency*

The CDQ is equipped with charging and discharging dust collecting systems and boilers with primary and secondary dust collectors. Final collecting by bag filters which emission is below 20mg/Nm<sup>3</sup> (licence condition, below 50mg/Nm<sup>3</sup>). Collected coke dust is supplied as fuel to the sinter plant.

Steam (93 bar) production is approximately 470 000 t/y and steam (8 bar) production is approximately 50 000 t/y. 93 bar steam is used mainly in Raahe Steel Plant's power plant which means approximately 15 MW electricity output from there.

Emissions into water are close to zero. PAH- and COD- (Chemical Oxygen Demand) values are marginal.

In addition, dry coke is a benefit in blast furnace operation and the handling/preparation costs of dry coke are lower particularly during winter conditions.

#### *Cross-media effects*

No dusty quenching steam clouds in the atmosphere and community compared to wet quenching and utilization of thermal energy

### *Driving force for implementation*

Environmental reasons, stable coke quality (low moisture content) and energy efficiency impacts.

### *Economics*

The investment costs are high but the energy efficiency is also high compared to coke wet quenching. In our case the power plant's turbine capacity does not need any further investments.

### *Reference plant*

Coke Plant Raahe, Ruukki Production, Rautaruukki Oyj, Finland.

### *Position in the present BREF*

I.6.3,PI.7.

I/4.4

## **Low slag volume blast furnace practice using sinter as raw material**

### *Description of the techniques*

In the end of the 1980's professor J-O. Edström developed in laboratory scale a new type of iron ore sinter. He named it "Optisinter". This new sinter had exceptional high iron content 65 % Fe. Based on the "Optisinter" Ruukki some years later developed a new version of high iron sinter and introduced it in full scale production at Raahe sinter plant. High iron sinter practice has been continuously in use over 10 years at Raahe sinter plant. Sinter iron content has varied 61 % to 63.5 % Fe depending on raw materials.

The use of high iron sinter in blast furnace has made possible the low slag volume practice (about 200 kg/ton HM) in ironmaking process at Raahe Steelworks. Normal slag volume in European blast furnaces, which are using mainly sinter as iron burden, is between 250 kg/ton HM and 300 kg/ton HM.

### *Applicability*

Low slag volume blast furnace practice using sinter as raw material is applicable to other plants, but it needs development work and fundamental understanding of effects of different iron ores to the sinter quality.

### *Environmental impacts and benefits, energy efficiency*

Low slag volume in blast furnaces has made possible to develop productivity and energy efficiency of ironmaking process so that Ruukki's Raahe Steelworks two blast furnaces have superior productivity among the European blast furnaces. Reductant agent consumption is also very low, which is reducing environmental impacts. 50 kg/ton HM less slag in BF process reduces normally 5 kg/ton HM coke which is 15 kg/ton HM less CO<sub>2</sub> emissions.

### *Cross-media effects*

Low slag volume practice reduces the need of BF slag recirculation.

### *Driving force for implementation*

To improve productivity and energy efficiency.

### *Economics*

The economical benefits are connected with increased productivity and reduced energy consumption.

### *Reference plant*

Ruukki Production, Raahe Steelworks, Finland.

### *Position in the present BREF*

Pos. 1.7.1.

I/4.5

## **Recovering of heat from cowpers**

### *Description of the techniques*

A cowper is a large scale heat exchanger used to heat up the air blast to the Blast Furnace process. It consists of a burner, a combustion chamber, a dome and a chequer chamber filled with refractory chequer bricks for heat storage and heat transfer. The temperature of the oxygen enriched air blast for the Blast Furnace process is raised from 180 °C to 1180 °C.

Normal practice at a Blast Furnace is to use three Cowpers. Two Cowpers are normally heated and one is used for heating the air blast. In the heating stage Blast Furnace gas is burned in the combustion chamber of the Cowpers and the heat is transferred to the bricks in the chequer chamber. The temperature of the waste gases leaving the Cowper is normally 200-350 °C which still corresponds to a fairly high amount of energy. To recover this energy Ruukki has installed heat exchangers where the heat from the waste gases are used to preheat the Blast Furnace gas to be burned in the cowper. In Ruukki's case the heat exchangers are of the gas to gas type which differs from normal practice.

### *Applicability*

The practise of using cowpers to heat the blast air is applicable to all Blast furnaces.

### *Environmental impact and benefits, energy efficiency*

The NO<sub>x</sub>, SO<sub>2</sub>, CO<sub>2</sub> and CO emissions are low. The emission levels are:

NO<sub>x</sub> 20-25 g/t iron

SO<sub>2</sub> 70-100 g/t iron

CO<sub>2</sub> 0,4-0,5 g/t iron

Significant energy savings are reached by using the combustion gas to preheat the blast furnace gas. The saving from this technique is about 170 MJ/t steel.

### *Cross-media effects*

The blast furnace gas saved in the effective heating of cowpers can be used to produce electricity.

### *Driving force for the implementation*

- Increased energy efficiency.
- Low emissions.
- High productivity of blast furnaces.
- Low need of reducing agents in the blast furnaces.

### *Economics*

The economical benefits are connected with increased productivity and reduced energy consumption.

### *Reference plant*

Ruukki Production, Raahe Steel Works, Finland.

### *Position in the present BREF*

Pos. I.7.3, P1.4, I.7.5.

## **SSAB Oxelösund BF Practice, Sweden**

Energy efficient pellets based blast furnace practice with low slag volume and oxy-coal injection

### **Blast furnace objects at SSAB, Oxelösund Works – Blast furnace No 2 and 4, Sweden**

- Oxy-coal-injection technique at the blast furnace.
- 100 % pellet-operation in the blast furnace.
- Low slag volume in the blast furnace (pellet practice).
- Briquettes – a way to be independent of a sinter plant to recycle in-plant fines.

I/4.6

### **Oxy-coal injection technique at the Blast Furnace**

#### *Description of the techniques*

Both blast furnaces at SSAB Oxelösund are operated with pulverized coal injection since 1987. The furnaces no 2 and 4 have hearth diameters of 6.9 and 8.7 m respectively and have restrictions concerning hot blast temperature and availability of oxygen for enrichment of the hot blast. The pulverized coal at BF no 4 is since 1993 injected with an oxy-coal injection technique developed by SSAB and MEFOS (Ref 1). A swirl type, coaxial, oxy-coal lance improves the combustion of the coal. The oxy-coal lances has eliminated earlier experienced problems with lance clogging and thereby improved the distribution of the coal between the tuyeres of the blast furnace.

#### *Applicability*

The method is applicable at all blast furnaces equipped with pulverized coal injection and oxygen enrichment.

### *Environmental impact and benefits, energy efficiency*

With this technique it has been possible to increase the coal-injection with approximately 20 % and correspondingly decrease of the coke rate. The function of the equipment for cleaning of the blast furnace gas (electrostatic precipitators) has improved and there is also a positive effect on the permeability in the blast furnace that together with the improved coal distribution improves the whole blast furnace performance.

### *Cross-media effects*

Reduced coke consumption and improved cleaning of blast furnace gas.

### *Driving force for implementation*

The driving forces are both economic and environmental benefits as a result of improved BF operation.

### *Economics*

-

### *Reference plant*

Blast furnace no 4 at SSAB Oxelösund AB, Sweden.

### *References*

1. Wikström J O, Sköld B E and Kärstrud K, "SSAB/MEFOS oxy-coal system – 3 years of industrial experience", 79th Steelmaking and 55th Ironmaking, Pittsburgh, March 24-27, 1996.

### *Position in the present BREF*

Pos. I.7.1.4.

## I/4.7

### **100 % pellets operation at the Blast Furnace**

#### *Description of the techniques*

SSAB Oxelösund operates on 100 % pellet burden. The pellet used has high iron content ( $Fe_{tot} = 66.6-66.8 \%$ ), low gangue content and high reducibility.

#### *Applicability*

This method is applicable when pellets are available on the market.

#### *Environmental impact and benefits, energy efficiency*

When the sinter plant is closed the emissions to air are decreased.

#### *Cross-media effects*

The pellets used at the moment are produced from magnetite concentrate and the oxidation of magnetite to hematite during burning decreases the energy consumed in the pellet plant. Rest products like flue dust, coke breeze, mill scale and filter dust that normally are recovered in a sinter plant and must be handled in another way, see object I/4.9.

### *Driving force for implementation*

The driving forces for implementation are environmental benefits and avoidance of investment and operative costs of a sinter plant.

### *Economics*

-

### *Reference plant*

BF No. 2 and 4 in Oxelösund, Sweden.

### *Position in the present BREF*

Pos. I.7.1.

I/4.8.

## **Low slag volume using 100 % pellets**

### *Description of the techniques*

The average slag volume at the two BF in Oxelösund 2004 was 151 kg/ton HM. The main reason to the low slag volume today is the use of pellets with high iron content ( $Fe_{tot} = 66.6-66.8\%$ ) and low gangue content. Before 1996 a low slag volume of around 150 kg/ton HM was achieved with a burden of 40 % pellets and 60 % of high iron content ( $Fe_{tot} = 62\%$ ) sinter. Other important factors are moderate ash content of coke and low ash content of coal for injection.

### *Applicability*

This method is applicable by using pellets or sinter feed with high iron content available on the market as well as coke and coal with low ash.

### *Environmental impact and benefits, energy efficiency*

Decreased consumption of reducing agents in the Blast Furnace (BF). A normal slag volume for sinter based blast furnace production is about 100 kg/ton HM higher. This corresponds to approximately 20-25 kg/ton HM decrease of reducing agents, which will correspond to decreased CO<sub>2</sub> emissions of 60-80 kg/ton HM.

### *Cross-media effects*

Decreased raw material consumption and decreased volume of slag that has to be recycled.

### *Driving force for implementation*

The driving forces for implementation are environmental benefits and decreased demands of reducing agents.

### *Economics*

The economics is connected with decreased consumption of reducing agents.

*Reference plant*

BF No. 2 and 4 in Oxelösund, Sweden.

*Position in the present BREF*

Pos. I.7.1.

I/4.9.

**Briquettes - a way to be independent of a sinter plant to recycle in-plant fines**

*Description of the techniques*

Two types of cold bonded agglomerates are made: one briquette type with the carbon containing materials Blast Furnace (BF) flue dust and coke breeze and one briquette type with iron containing materials as pellets fines, fine scraps, mill scales, filter dusts etc. Today the briquettes are produced in a block making machine with cement as a binder. The production and recycling of cement bonded briquettes started around 1975 and since 1993 the briquettes have been a notable amount of the BF burden. The block machine technique started late in 1996.

The briquetting plant belongs to established technology and it consists of a raw material handling station, a block making machine and a curing chamber. The material handling part includes silos for fines of dry dust and binder, bins for coarser moisture material and a mixer. The briquetting blend is transported to the block-making machine and the produced briquettes are transferred into the curing chamber. After 24 hours curing the hardening of briquettes will be further hardened outdoors for 3 weeks before they are charged into the blast furnace.

The average amount of briquettes charged during 2004 was 51 kg/ton HM together with a burden of 100 % pellets. The amount of briquettes is dependent of the availability of inplant materials and there is earlier experience with amounts above 80 kg/ton HM in the burden.

*Applicability*

The production of briquettes and use as BF burden is reliable and works well.

*Environmental impact and benefits, energy efficiency*

Recycling of in-plant fines decreases the deposits on landfill and the use of virgin material. Briquettes together with a virgin burden of 100 % pellets the independence of a sinter plant has obvious environmental benefits.

*Cross-media effects*

-

*Driving force for implementation*

The driving forces for implementation are environmental benefits and avoidance of space and costs for landfill as well as the cost of a sinter plant.

*Economics*

-

### *Reference plant*

The briquetting plant is operated by SSAB Merox and is situated in the industrial area of SSAB Oxelösund, Sweden.

### *Position in the present BREF*

Pos. I.5.5.2.

### **SSAB-Luleå, BF practice, Sweden**

High availability, low slag volume, energy efficient (coke and coal) BF-practice.

- Availability > 99 % (nearly 100 %).
- Slag volume 150-170 kg/ton Hot Metal (HM).
- Reducing agents (coke and coal) at the level of 470 kg/ton HM.

### **Blast furnace objects at SSAB, Luleå Works, Sweden**

- 100 % pellet operation in the blast furnace.
- Low slag volume in the blast furnace.
- Briquettes, a way to recycle in plant fines.

I/4.10

### **100 % pellet operation**

#### *Description of the techniques*

SSAB Tunnplåt in Luleå operates on 100% pellet burden. The pellet used has high iron content ( $Fe_{tot} = 66.6-66.8\%$ ), low gangue content and high reducibility.

The pellets delivered have a temperature of 10-60 °C and are almost dry when they reach SSAB in Luleå.

#### *Applicability*

This method is applicable by using pellets with high iron content available on the market.

#### *Environmental impact and benefits, energy efficiency*

Decreased emissions to air when closing down the old sinter plant and decreased consumption of reducing agents in the BF. Increased reducibility results in increased gas efficiency and subsequently the consumption of reducing agents and the CO<sub>2</sub> emission decrease with more than 10 kg/ton HM and 30 kg/ton HM, respectively.

#### *Cross-media effects*

The pellets used at the moment are produced from magnetite concentrate and the oxidation of magnetite to hematite during burning decreases the energy consumed in the pellet plant. Rest products like flue dust, coke breeze, mill scale and filter dust that normally are recovered in a sinter plant and must be handled in another way, see object I/4.9.

#### *Driving force for implementation*

The driving forces for implementation are environmental benefits, improved BF operation and avoidance of high investment costs, in sinter plant.

#### *Reference plant*

BF No. 3 in Luleå, Sweden.

#### *Position in the present BREF*

Pos. I.7.1.

I/4.11

### **Low slag volume using 100 % pellets**

#### *Description of the techniques*

The average slag volume at BF No. 3 in Luleå 2004 was 159 kg/ton HM. The main reason to the low slag volume is the use of pellets with high iron content ( $F_{e_{tot}} = 66.6-66.8\%$ ) and low gangue content. Other important factors are moderate ash content of coke and low ash content of coal for injection.

#### *Applicability*

This method is applicable by using pellets with high iron content available on the market as well as coke and coal with low ash.

#### *Environmental impact and benefits, energy efficiency*

Decreased emissions to air when closing down the old sinter plant and decreased consumption of reducing agents in the BF. A lower slag volume of 100 kg/ton HM corresponds to approximately 20-25 kg/ton HM of reducing agents, which will correspond to decreased CO<sub>2</sub> emissions of 60-80 kg/ton HM. Decreased raw material consumption and decreased volume of slag that has to be recycled are other positive effects.

#### *Cross-media effects*

-

#### *Driving force for implementation*

The driving forces for implementation are environmental benefits and avoidance of high investment costs.

#### *Reference plant*

BF No. 3 in Luleå, Sweden.

#### *Position in the present BREF*

Pos. I.7.1.

I/4.12

### **Briquettes - a way to recycle in-plant fines**

### *Description of the techniques*

Cold bonded agglomerates mainly consisting of BF flue dust, filter dust, coarse particles of BOF sludge, scrap fines and briquette fines are produced in a block making machine with Portland cement as binder. The production and recycling of briquettes started in 1993.

The briquetting plant belongs to established technology and it consists of a raw material handling station, a block making machine and a curing chamber. The material handling part includes silos for fines of dry dust and binder, bins for coarser moisture material and a mixer. The briquetting blend is transported to the block-making machine and the produced briquettes are transferred into the curing chamber. After 24 hours curing the hardening of briquettes will be further hardened outdoors for 28 days before they are charged into the blast furnace.

The average amount of briquettes charged during 2004 was 39 kg/ton HM.

### *Applicability*

The production of briquettes and use as BF burden is reliable and works well.

### *Environmental impact and benefits, energy efficiency*

Recycling of in-plant fines decreases the deposits on landfill and the use of virgin material. The content of metallic iron and C (average C content 2004 was 16.7 %) reduces the rate of reducing agents (coke and coal) that has to be added. It has a basicity  $B_2 = \text{CaO}/\text{SiO}_2$  of approximately 2.8 leading to decreased demand of limestone ( $\text{CaCO}_3$ ) as well but will increase the slag amount to some extent.

### *Cross-media effects*

-

### *Driving force for implementation*

The driving forces for implementation are environmental benefits and avoidance of space and costs for landfill.

### *Economics*

-

### *Reference plant*

The briquetting plant is operated BDX and is situated in the industrial area of SSAB Tunnpålar in Luleå, Sweden.

### *Position in the present BREF*

Pos. I.5.5.2.

## **I/5**

### **Utilization of ironmaking and steelmaking slags as products**

#### *Description of the techniques*

Blast Furnace slag and LD-slag are produced as co-products together with iron and steel. A lot of research and development work has been done in order to know the prop-

erties of these slags better and to find best applications and customers for the slag products.

Blast Furnace slag, especially as granulated, has excellent properties for many purposes. It is used as a raw material in cement production to substitute clinker, as a road construction material, as a thermal insulation material in building and as a fertilizer in agriculture.

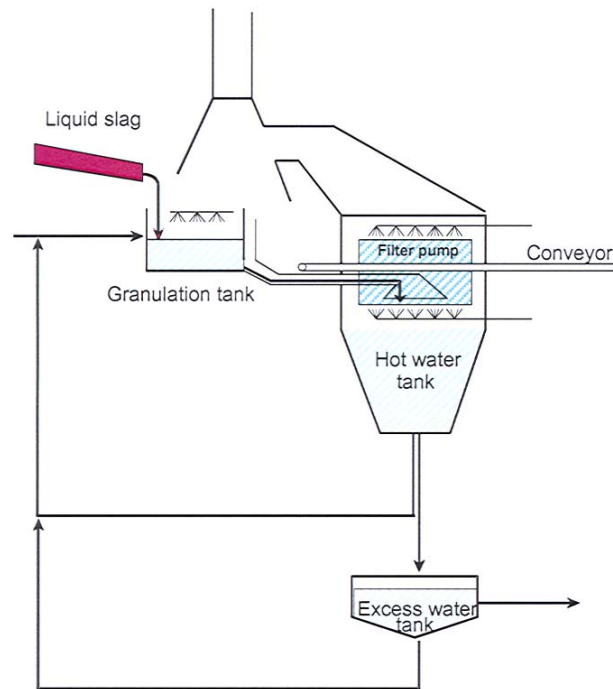

Figure 10. Granulation

LD-slag is used as a raw material of steel plant and as a fertilizer in agriculture. The whole slag production can be utilized as special products.

#### *Applicability*

This method is applicable in all steel plants, different local conditions can influence to the rate of utilization and the sales volume on slag products for different purposes.

#### *Environmental impacts and benefits, energy efficiency*

The use of slag in cement production to replace clinker reduce CO<sub>2</sub>-emissions and the use of energy in cement production. The replacement of a tonne of clinker with a tonne of granulated blast furnace slag will avoid an emission of 0,8 tonne of CO<sub>2</sub>. If the whole world production of granulated BF slag (160 Mt/a) should be used to replace clinker, the reduction of CO<sub>2</sub> emission should be 130 Mt/a. In Finland cement industry used (2003) 110 000 t blast furnace slag, thus avoiding emissions of 88 000 t CO<sub>2</sub>. This was 14.7 % of potential possibilities, the whole blast furnace slag production was 750 000 t representing potential of 600 000 t emission reduction.

In road construction slag replace materials taken from nature and the emissions of this activity can be avoided. The saving of non-renewable natural material can be twice the volume of slag because of better load bearing and thermal insulation properties.

In agriculture the use of slag products reduce the use of limestone mined for liming purposes. Also the CO<sub>2</sub> emissions of limestone can be avoided.

Recycling of slag in ironmaking process decrease the need of virgin raw materials as limestone, olivine and iron ore.

#### *Cross-media effects*

As a part of environmental benefits the use of nature resources decrease and the impacts to the earth are less harmful.

#### *Driving force for implementation*

Economics, incomes from the sales of slag products.

Environmental benefits, reduction of CO<sub>2</sub>-emissions, save of nature resources (rock, stone, sand).

#### *Economics*

Incomes from sales of slag products, avoidance of landfill costs.

#### *Reference plant*

Rautaruukki Oyj, Ruukki Production, Raahe Steel Works, Finland.

#### *Position in the present BREF*

Pos. I.7.1.6.1.

## **I/6**

### **Automatic ladle lid system**

#### *Description of the techniques*

Steel ladles are used for secondary treatments and transporting the liquid steel from BOF converters to continuous casting. In normal practice the ladles are not covered during ladle treatments and transportation, but a lid is commonly used to prevent extra heat losses during continuous casting. After casting and ladle maintenance the ladles in operation are heated with burners, typically with coke oven gas or natural gas to keep them hot for next heat.

At Raahe Steel Works from eight to nine ladles are in operation simultaneously. The ladles are equipped with lids which are removed only during tapping of the BOF and during ladle treatments. No burners are needed to keep the ladles hot after ladle maintenance. BOF converters and secondary metallurgy stations are equipped with lid stands where the lid is automatically placed or removed on/off the ladle depending on process step. The system is so called hinged lid system, which also enables slag tapping after casting without removing the lid.



Figure 11. Automatic ladle lid system

#### *Applicability*

The automatic ladle lid system is basically applicable to all steel plants. There are different technical designs to implement the system to particular conditions of a steel plant.

#### *Environmental impact and benefits, energy efficiency*

Because less heat is lost during ladle cycle time, the average tapping temperature has decreased with 10 °C. Lower tapping temperatures enables 8 kg/t higher scrap rate at BOF with no extra fuel added and thus higher productivity. Another possibility is to produce steel with 8 kg/t less hot metal which is equivalent of 15 kg/t reduction in CO<sub>2</sub> emissions. The deviation of tapping temperatures is 4 °C smaller, which is significant for stable process control. Steel temperatures are more stable during the whole steel-making process, which reduces interrupted casts at continuous casting. The ladles are practically free from steel and slag sculls. No extra energy is needed at ladle maintenance area, which allows us to use coke oven gas at other applications in the steel works.

#### *Cross-media effects*

The lids reduce dust emissions and direct heat radiation from steel ladles during transportation. Refractory wear of converters and ladles is slightly improved.

#### *Driving force for implementation*

Driving forces for the investment are increased production, better process control with improved yield, increased energy efficiency and cost savings.

## Economics

The automatic lid system gives the steel maker significant reduction of production costs.

## Reference plant

Ruukki Production, Raahel Steel Works, Finland.

## Position in the present BREF

(Pos. I.8.1.)

## I/7

### Automated BOF tapping practice

#### Description of the technique

Automation of the BOF tapping practice at SSAB Tunnplåt AB's steel plant in Luleå was gradually introduced during the late 1990's. The first step was implementation of quick and direct tapping (QDT), later followed by automation of the whole tapping sequence, including tapping of slag.

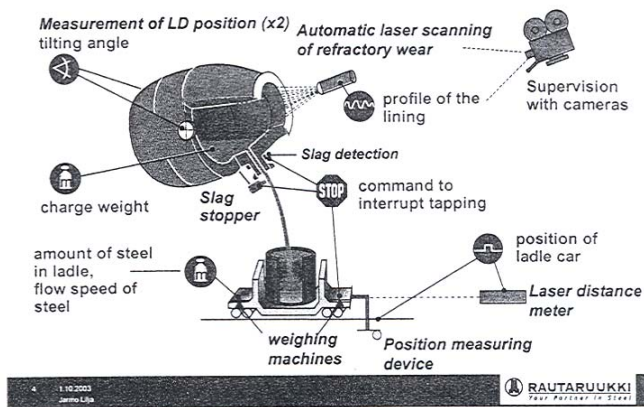

Figure 12. Schematic of the automatic tapping system (from paper presented by Jarmo Lilja at SCANMET II, 6-9 June 2004, Luleå, Sweden)

By utilizing the available SUB-lance system steel temperature and a carbon content estimate can be obtained without having to tilt the converter into a horizontal position. Hence, tapping can be commenced within 2-3 minutes after end of blow, depending on time for post-stirring. During 2004 around 75 % of the heats were tapped within 3 minutes.

The tapping sequence, initiated by the operator, consists of the following automated steps:

- steel tapping,
- slag coating, *and if necessary also slag-splashing,*
- slag tapping.

An infra-red camera, which can distinguish between steel and slag, is used to determine when slag enters the tap stream and when to automatically terminate steel tapping.

### *Applicability*

The practice is easily applicable at any BOF plant which is equipped with systems for fast and accurate recording of temperature and carbon content of the steel at end of blow, as well as for slag detection during tapping.

### *Environmental impacts and benefits, energy efficiency*

The automated tapping practice has several major environmental benefit;

- it lowers the aimed tapping temperature for the steel with some 15 °C. This allows for an increased scrap ratio, hence a decreased hot metal ratio, in the charge. With 15 °C lower tapping temperature it is *possible* to reduce the hot metal ratio with some 9 kg per ton of crude steel, equivalent to a *possible* total reduction in CO<sub>2</sub> production at the plant of around 16 kg CO<sub>2</sub> per ton of crude steel.
- by avoiding tilting the converter into a horizontal position for sampling after end of blow, the emission of hot gases and dust are reduced.
- with accurate timing of termination of the steel tap, less steel is left in the converter and tapped together with slag into the slag pot. Less steel in the slag pot results not only in a stabilized process yield, but also in less dust emissions when the pots are emptied.
- a higher degree of slag coating leads to longer lining life and reduces need for ceramic materials. A rough estimate is that automated tapping, in it's self, has led to a 20 % increase in lining life.

The energy efficiency is not only improved by an overall increase in productivity due to shorter times between steel tapping, but also by a reduced tapping temperature, which can be utilized for an increase in scrap re-circulation, as well as by an improved steel yield.

### *Cross-media effects*

No negative side effects have been recorded with this new practice.

### *Driving force for implementation*

Driving forces for an increased degree of automation of the tapping practice where:

- stabilizing and increasing steel production, increased time utilization.
- improved process control.
- improved working environment.
- increased lining life.

### *Economical benefits*

The economical benefits are mainly connected with an increased productivity, decreased maintenance costs and reduced refractory wear.

### *Reference plant*

SSAB Tunplåt AB, Luleå Works, Sweden. Ruukki Production, Raahe Works, Finland.

### *Position in the present BREF*

(Pos. I.8.1.)

## **Continuous measurement of dust emissions from secondary dedusting system**

### *Description of the techniques*

A continuous dust measurement system is installed in the exhaust gas system after the secondary dedusting filter. There are 2 instruments for measuring dust emissions in the channels after the secondary dedusting filter and 2 in the lanterns as well. All these instruments are manufactured by PCME, Great Britain. The measuring principle is gravimetric ( $\text{mg}/\text{m}^3$ ). They are calibrated once per year by an external company. The collected data are saved in SSAB's own database. The control of the filter function is done by SSAB's own operators. Revision is made once per year. The fluorescence method is used to detect leakage.

Also dust emissions from the LD furnace (excluding primary off gas) is closely monitored and reported as an environmental performance during three separate process phases: charging, blowing and other time.

### *Applicability*

The practise is applicable both for existing and new steel plants.

### *Environmental impacts and benefits, energy efficiency*

Results from the dust measurements after the secondary dedusting filter are summarized and reported as weekly averages (see diagram), but may be extracted on other-time basis. The results are given in  $\text{mg}/\text{m}^3$ . Normal values are 1-2  $\text{mg}/\text{m}^3$ .

Dust emission from the LD-process, excluded primary and secondary dedusting, are reported for each heat and also summarized as monthly averages. The intervals for dust-emissions are following:

During charging 25-30  $\text{mg}/\text{m}^3$

During blowing 12-20  $\text{mg}/\text{m}^3$

During other time 10-15  $\text{mg}/\text{m}^3$

The reporting happens by index counting with following principles:

Index 1      The measured dust values are less than the interval

Index 2      The values are inside the interval

Index 3      The values are worse than the interval

The total index has varied monthly wise between 1.6 and 2.1 during the year 2004.

The measured emissions are followed to observe any deviation from normal values or exceeding limit values. Corrective actions may (can) then be taken without delay.

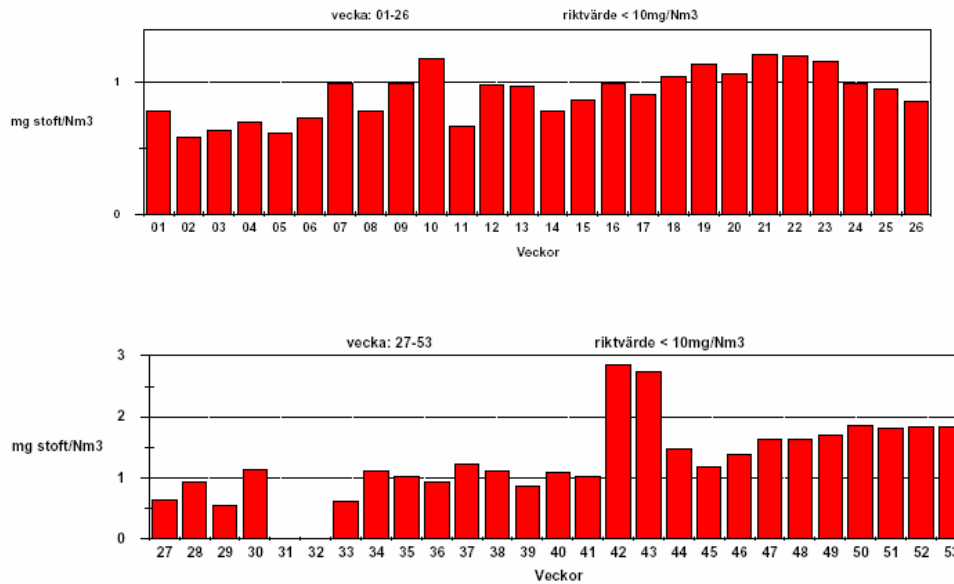

Figure 13. Dust amount from secondary dedusting system

*Cross-media effects*

-

*Driving force for implementation*

The driving force is the company's intention to be a good environmental performer, to follow the rules and regulations given by the authorities and to have a system for prompt reaction to poor dedusting performance. Early corrective action also has an economical value.

*Economics*

-

*Reference plant*

Reference plant is SSAB Oxelösund AB, Sweden.

*Position in the present BREF*

Pos. I.8.2.2.1.1.3.

**I/9**

**Direct tapping from BOF**

*Description of the techniques*

Direct tapping has been widely used Ruukki production, Ovako Koverhar since 2001. It concerns nearly all steel qualities except some special steels. The share of direct tapping is today 99 % of all melts.

Normally expensive facilities like SUB-lance or DROP IN sensor-system are used to be able to tap without waiting for chemical analysis of samples taken (direct tapping). Koverhar has developed a practice to achieve direct tapping without such facilities. In

the practice the carbon is directly blown down to 0.04 % and simultaneously the bath temperature to a reasonable low target. Before tapping both T and oxygen activity are measured for further actions.

For succeeded direct tapping are some preconditions needed, like a suitable HM-analyse and slag stopping facilities. The availability of a ladle furnace makes the practice easier to realize.

The re-blow-rate at the Ovako Koverhar plant is today approximately 5 %.

The technology belongs to the list “Established techniques”.

#### *Applicability*

The practice is principally applicable in BOF-plants with certain preconditions. The realizing of the practice without extra facilities means several years of development work.

#### *Environmental impacts and benefits, energy efficiency*

The advantages of direct tapping practice are mainly to do increased energy efficiency. The bath cooling after blowing has reduced with 20 °C. At the same time the tap-to-tap-time has shortened by 20 %. That means a significant increase in productivity. Because of improved thermal economy the volume of scrap has increased by 5 % compared with non direct tapping practice. This means a reduction of CO<sub>2</sub>-emission by approximately 15 kg/t.

The lining life has increased by about 10 %.

Because of the increased lining life and bigger amount of re-circulated material (scrap) also a reduced environmental impact is a fact.

#### *Cross-media effects*

-

#### *Driving force for implementation*

- Increased energy efficiency.
- Increased productivity.
- Cost savings.
- Reduced environmental impact.

#### *Economics*

The economical benefits are connected with increased productivity, reduced energy consumption and reduced refractory ware.

#### *Reference plant*

Ovako Koverhar, Finland.

#### *Position in the present BREF*

Pos. I.8.3, Pl.3.

## I/10

### **Efficient use of big amounts of scrap in converter process and efficient utilization of scrap arising at the works**

#### *Description of the techniques*

Annually 0.75 Mt (> 250 kg/ton steel) of scrap is used at Raahe Steel Works. 0.4 Mt of scrap is produced internally and 0.35 Mt purchased. All internally produced scrap has been fully recycled. The new scrap terminal was taken into operation at the beginning of 2002. Before that the maximum amount of scrap was approximately 200 kg/ton steel. There are four different recipes and nine different scrap qualities in use. Scraps are qualified on the basis of their weight and chemical analyses. In the scrap terminal there are separate bunkers for each different kind of scrap. The reason for four different recipes is that special steel qualities require scrap with well-known chemical composition of which is well-known. For those purposes only the internal scrap qualities are suitable.

#### *Applicability*

The practice is in principle applicable in all BOF-plants. BOF-plants have to classify scrap qualities on the basis of weight and chemical analyses.

#### *Environmental impacts and benefits, energy efficiency*

A higher degree of scrap in the BOF converter results in an overall improved environmental and energy efficiency. Clean surroundings outside the steel plant due to the high recycling degree of scrap.

#### *Cross-media effects*

Increased steel production with remaining hot metal products.

#### *Driving force for implementation*

- Increased steel production.
- Cost savings.
- Reduced environmental impact.

#### *Economics*

Increased steel production means reduced amount of purchased slabs and better profitability.

#### *Reference plant*

Ruukki Production, Raahe Steel Works, Finland.

#### *Position in the present BREF*

Pos. I.9.1.1.

## **Filter plant service and monitoring system**

### *Description of the techniques*

The EAF-steel works consist of a whole building evacuation and a separate dust suction from the EAF-furnace itself. Scrap preheating is in use, mainly because of snow and ice. The filter plant installation is equipped with an efficient spark arresting and cyclones, from which the dust > 5 micron, 30 % of the total amount, is charged back to the EAF together with the scrap. The main fans (average 620 000 Nm<sup>3</sup>/h) have a rotation speed control. The baghouse has a conservative (large) dimensioning (9 400 m<sup>2</sup>) and the filter bags are normal needle felt type with PTFE-coating. The filter bags are cleaned with a pulse-jet system. Continuous monitoring and a careful service of the baghouse works on the following ways:

- Monitoring of dust emission, no real calibration. Important is to detect change of emission level (leakage in one bag can immediately be detected).
- Continuous monitoring via 2 separate instruments:
  - Tribometric measuring system, SINTROL.
  - An optical measuring system, SICK.
- Visual check of all bags for sparkholes, intensity: every second week, one man three hours. Clean side of the bags are kept totally clean. Holes of 1 mm diameter can be detected without difficulty so no fluorescence method is needed.

### *Applicability*

The facilities and the monitoring and control system are well applicable both to existing and new plants with following precondition:

- Effective spark arresting.
- Easy access to cleanside chambers.

### *Environmental impacts and benefits, energy efficiency*

#### Emissions

- Dust: < 1 mg/Nm<sup>3</sup>, measured according to EN13284-1 (2002), (low filtering velocity, off-line cleanings, no holes).
- Dioxins: < 0,1 ng/Nm<sup>3</sup>, measured according to EN1948-1...3 (>95 % is separated due to low gas temperature at filter and effective filtering of the particulate material).

#### Energy need

- Electricity 20 kwh /t liquid steel, scrap preheating gives back roughly the same amount of energy.

### *Cross-media effects*

Clean surroundings inside and outside of the steel plant.

### *Driving force for implementation*

Environmental impact.

*Economics*

-

*Reference plant*

Ovako Imatra, Finland.

*Position in the present BREF*

Pos. I.9.2.2.1.

**I/12**

### **Avoiding dust formation when emptying slag pots**

*Description of the techniques*

The highly basic slag from stainless steel plants contains dicalcium silicate,  $\text{Ca}_2\text{S}$ , which undergoes a phase transformation during cooling. The transformation includes a certain increase in volume. Hence, the slag will disintegrate and form dust which, by the help of winds, can be carried to places far outside the plant area.

By quenching of the slag, the phase transformation can be suppressed and no dusting will occur.

At Sandvik, the problem with dust formation has been solved by emptying slag pots, filled with hot and partially liquid slag, in a box surrounded by a retaining dike. 12 m<sup>3</sup> of water is then flooded over the slag. The quick drop in temperature together with binding of small particles with water has proven to eliminate spreading of dust over large areas.

The water itself is recirculated via a basin.

*Applicability*

The described technique can be used whenever the slag is hot enough to not yet have undergone the dust forming phase transformation. I.e. it is used for all slag pots, EAF and AOD, except for the one in which the remaining ladle slag from the continuous caster is emptied. All in all, 90 % of the produced slag is processed in the described way.

Pots with slag from the teeming ladle are put in a watering equipment, i.e. the pots are filled with water and are then left until they are cooled down and the slag is soaking wet.

*Environmental impact and benefits*

The previous practice caused clouds of dust rising from the pot emptying area. The clouds were sometimes caught by the wind and were carried into the town or out over the lake where the dust fell out onto cars or boats.

According to estimations from the early implementation of the technique, the dusting was reduced by more than 90 %. Since only the slag from the pot from the teeming ladle is not processed in an optimal way, the reduction in dusting is probably close to 100 %.

As a measuring index of the dusting problem, the number of cars or boats around the plant that have to be cleaned can be used. 2002, in total 80 cars and boats had to be cleaned. With the new technique of 2004, no cars or boats were affected by dust from the emptying of slag pots.

The results so far have been outstanding in terms of environmental and goodwill aspects.

#### *Cross-media effects*

The new practice has not involved any negative side effects apart from the fact that more recirculated water is used.

It is likely that less amounts of products like wax and car polish are used at car cleaning stations in town.

#### *Driving force for implementation*

The driving forces for implementation are environmental and economical. Goodwill aspects are not the least important force in this case.

#### *Economics*

The cost for washing cars 2002 were roughly 150 KSEK. In total 80 cars and boats had to be cleaned. With the new technique of 2004, no cars or boats have had to be washed because of dust from the emptying of slag pots.

#### *Reference plant*

Sandvik Materials Technology, Sandviken, Sweden.

#### *Position in the present BREF*

Pos. I.9.1.7.

## **I/13**

### **Determination of some environmental sensitive elements in waste water**

#### *Description of the techniques*

The sample is preserved with nitric acid and digested in a microwave oven to dissolve residues. As internal standard Sc and Te are used. The solution is pre-concentrated in an ultrasonic nebulizer and nebulized into an ICP-OES where the intensities of the emitted light of the elements are measured. The calibration is performed on a matrix containing MilliQ water with addition of reference solutions. The following elements are determined simultaneously:

Al, Cd, Co, Cr, Cu, Fe, Mn, Mo, Ni, P, Pb, V, Zn.

#### *Applicability*

Water from different sources e.g. wastewater, drinking water etc.

#### *Environmental impacts and benefits, energy efficiency*

The procedure is capable to determine levels below legislation requirements of today. Detection limits are shown in the table below:

Element	Detection limit (mg/l)
Al	0,002
Cd	0,00003
Co	0,0002
Cr	0,0001
Cu	0,0006
Fe	0,0001
Mn	0,00003
Mo	0,0002
Ni	0,0002
P	0,0018
Pb	0,0006
V	0,0006
Zn	0,00006

*Cross-media effects*

Quick and efficient technique using standard equipment.

*Driving force*

National and European legislation's.

*Economics*

Short time from observation of increased levels to corrective actions.

*Reference plant*

Sandvik Materials Technology, Sandviken, Sweden.

*Position in the present BREF*

Pos. I.9.2.2.3.

**I/14**

**Biological waste water treatment at coking plant**

*Description of the techniques*

The biological cleaning is of active sludge type. The basins are without mechanical mixing but with air injection in the bottom. Phosphate and caustic soda are added. Caustic soda for pH adjustment.

From the biological basins the water is going to settling where FeCl<sub>3</sub> and polymer are added for improved settling properties.

After the settling basins the water still contains some suspended solids. These are taken care of in a flotation process and finally a sandfilter before the clean water leaves to the sea. The capacity of the treatment plant is 45 m<sup>3</sup>/h.

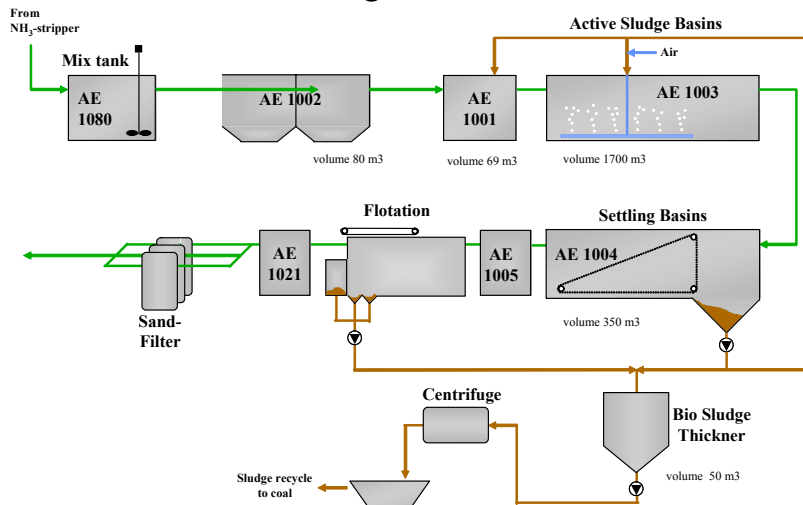

Figure 14 – Biological waste water treatment

*Applicability*

The process is applicable both in existing and new plants.

*Environmental impacts and benefits*

The technique is working very effectively from the environmental point of view. Typical values are following (mg/l in effluent water)

- TOC (Total Organic Carbon)            37, reduction > 95 %
- Phenols                                        < 0,1
- Ammonia                                        7.3
- Cyanide                                        < 0.1
- Suspended solids                            7.2

*Cross-media effects*

-

*Driving force for implementation*

Improved environmental impact.

*Environmental impact*

-

*Economics*

-

*Reference plant*

SSAB Tunnpåt AB, Luleå Works, Sweden.

*Position in the present BREF*

Pos. I.6.3, EP 11.

## *Objects in the BREF I - (Emerging techniques)*

I/1E

### **Frequency converted control of pumps and fans for cooling and cleaning water, and for off gas suction system at the LD-process**

#### *Description of the techniques*

The process control system allows for accurate control of water flow rates and off gas flow rates. Most pumps and fans are now frequency controlled and may therefore be set to any given rotation speed (rpm-value) to obtain the desired set point value for the flow rate. The set point can be different depending on the process status, i.e. blowing, tapping, waiting etc.

#### *Applicability*

The technique can be applied to the off-gas cleaning water, the cooling water of the hood and the lance, the off-gas fans and similar.

#### *Environmental impacts and benefits, energy efficiency*

The changes result in considerable savings in electrical energy as well as less maintenance costs and less production disturbances. Saving in electrical energy on year basis is 3.2 GWh. In CO<sub>2</sub>-reduction this means about 250 t/year.

#### *Cross-media effects*

-

#### *Driving force for implementation*

The driving force is mainly economical. The total savings potential for these changes, already started as well as planned, exceeds 500 KSEK per year in energy savings only (at a price of 0.30 SEK/kWh). In SSAB Oxelösund's case this can be achieved without investments. It is also a general ambition to be more and more energy efficient.

More energy savings may be obtained but, in our case, only after investments.

#### *Economics*

See point Drivning force for implementation.

#### *Reference plant*

Reference plant is SSAB Oxelösund AB, Sweden.

#### *Position in the present BREF*

Pos. I.8.5, I.8.2.2.4.

I/2E

### **Burning and recycling of dry waste dusts (radust-process), pilot plant**

#### *Description of the techniques*

(See also process lay-out)

The main parts of the equipment are:

- transport system for the dusts,
- stock station for the dusts,
- the weighing device for the dusts,
- pneumatic transporting system for the dusts to the reactor,
- reactor equipped with an oxy-fuel burner (AGA) and with tapping hole,
- post combustion and cooling system for the exhaust gas,
- cassette filter,
- additional device for instrumentation and for process control.

The capacity of the pilot plant is 20 000 t handled dusts as maximum. In case of Ovako Koverhar the main dusts are BF-dust and BOF-dust. The total yearly dust amount is 20 000, which corresponds to the maximum capacity of the plant.

The product coming out of the reactor consists approximately 50 % Fe in the form FeO/Fe<sub>3</sub>O<sub>4</sub>. Zinc-content is typically 0.1-0.2 % and K<sub>2</sub>O 0.5-1.0 %. The product is suitable for using back in the blast furnace.

The amount of cassette filter dust is 15-20 % of the dust input. Zinc-content in this dust is approximately 10 % and alkali (K<sub>2</sub>O+Na<sub>2</sub>O)-content 20-30 %. An outstanding company handles this dust.

The radust-pilot plant belongs to the list of “Emerging techniques”.

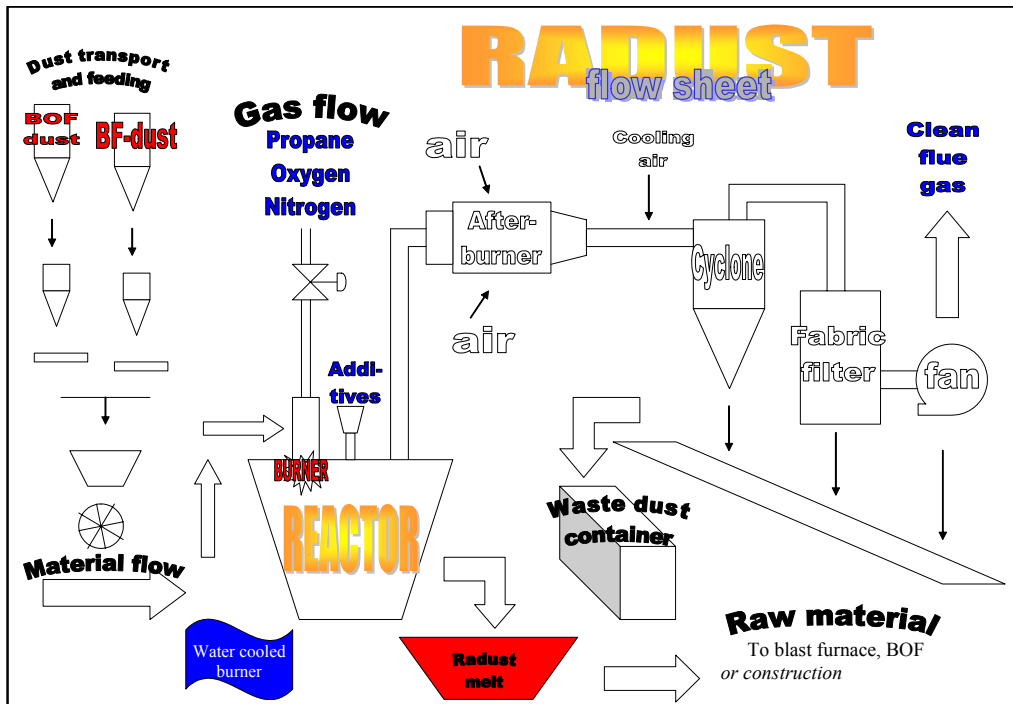

Figure 15. The Radust process

### *Applicability*

The metallurgy of the process is working principally well, but the equipment needs some further development work. The applicability of the process for handling of dry dusts will be good.

### *Environmental impacts and benefits, energy efficiency*

The BF-dust is classified as problematic dust. BOF-dust is a serious environmental disadvantage, but is anyway possible to put into the correspondent stocking yard.

The main part of these dusts will in the future be handled in the radust-plant, and because of that the environmental impact is remarkable.

The emissions after the cassette filter are less than 5 mg/Nm<sup>3</sup> and more than 50 % of the total S-amount remains in the cassette filter dust.

The energy efficiency of the process is on good level, because the need of external energy is minimal. (C-content in the BF-dust is 20-30 %).

### *Cross-media effects*

-

### *Driving forces for implementation*

- A significant environmental improvement.
- Savings in the total costs.
- Potential for engineering activities.

### *Economics*

The handling of the dusts by an outstanding company is more expensive compared with an own handling plant, especially when the whole capacity of the plant is in use.

### *Reference plant*

Ovako Koverhar, Finland.

### *Position in the present BREF*

Pos. I.8.5.

## **I/3E**

### **Production of stainless steel slag products**

#### *Description of the techniques*

Because of a large amount of slags, it is not reasonable to dump slags to landfill. Instead of dumping it is more reasonable and above all more sustainable to utilise slag materials for example as road construction materials. The ongoing slag project at Outokumpu Stainless Tornio Works has a target to utilise stainless steel slag to products at minimum costs. It has to take into consideration that BAT depends on the location of steel plant and the circumstances of specific area, which creates different kinds of demands for aggregates.

For stainless steel slag products, the following techniques or combination of techniques are considered as BAT.

Slag stabilization at the steel melting shop:

Stainless steel slag with a basicity of over 1.5 disintegrates into fine particles during cooling. The pulverization is due to transformation of  $2 \text{CaO} \cdot \text{SiO}_2$ . Such pulverization disturbs further utilization of slag and causes also environmental problems, such as dusting in the dumping station and slag yard. To prevent the pulverization, the slag must be stabilized with a stabilizer at the steel melting shop. Different kinds of stabilization techniques have been investigated at Tornio Works.

Quality control of production and products:

Earlier from the slag utilization point of view there was no target to the composition of stainless steel slag. Due to the ongoing slag project at Outokumpu Stainless Tornio Works, the slag composition is controlled for the products. Nowadays the composition of the molten slag is well known and optimised already from the steel melting shop. This is possible through quality control system. Following treatment technologies are also important:

- Minimizing and recovering of the metals from slag.
- Methods and equipments to assure slag quality during the handling.
- To get the aggregate into a competitive form, which can be a suitable product for the client.
- Fulfilment of the clients quality requirements.
- Constant analysis for certain aggregates.

Minimizing the leaching of chromium from slag materials:

A successful method to suppress chromium leaching is to bind chromium into stable slag phases. A “factor sp” spinel factor can be used for estimating the leaching of chromium from the slag. EU report “Decreasing the scorification of chrome” investigates the “factor sp”. The results of the slag investigations show that there is a relationship between the  $\text{MgO}$ -,  $\text{Al}_2\text{O}_3$ -,  $\text{FeO}_n$ - and  $\text{Cr}_2\text{O}_3$ -content in the slag and the leaching behaviour of chromium from the slag, which is described with the “factor sp”.

$$\text{“factor sp”} = 0.2 \cdot \text{MgO} + 1.0 \cdot \text{Al}_2\text{O}_3 + 1.0 \cdot \text{Fe}_{\text{total}} - 0.5 \cdot \text{Cr}_2\text{O}_3$$

For values of “factor sp” < 5 chromium leaching is high. Values of “factor sp” between 5 and 25 will result in low chromium leaching, mainly less than 0.05 mg/l. “Factor sp” > 25 results in nearly no chromium in the eluate (Cr below detection limit 0.01 mg/l).

Cooling:

Slag cooling has to be controlled so that the cooling does not change the stable mineral phase and increase the leachate characteristic. Different kinds of cooling methods have been investigated at Tornio Works.

Balance between metal separation and aggregates processing methods:

The metal separation process must be such that slag can be produced to product after the metal separation. There must be a balance between all the slag handling processes.

Crushing, screening and gravity and magnetic separation are examples for slag processing methods.

*Main achieved environmental benefits*

- Decreasing dusting at the dumping station and slag yard.
- Decreasing significantly the amount of wastes.
- Saving natural resource.

*Applicability*

New and existing plants.

*Cross-media effects*

Stabilizer consumption in the process.

*Driving force for implementation*

Minimization of wastes. Minimization of landfill costs.

*Economics*

Requires some investments.

Savings due to decrease of landfill costs. Incomes when the products get market.

*Reference plants*

At Outokumpu Stainless Tornio Works, Finland.

*Position in the present BREF*

Pos. I.9.5, I.9.1.7.

*Objects in the BREF II - (Established techniques)*

**II/1**

**Hot charging of blooms into the reheating furnace**

*Description of the techniques*

Percentage of charging via hot route was during 2004 as high as 93 %. The other essential figures at the same time period were:

- Engineering steel grades, billets/heavy bars: 65/35 %.
- T-range at direct hot charging 700-900 °C.
- Specific energy consumption 0.94 GJ/t.

To make a figure of 93 % for direct hot charging grade possible, a good surface quality of blooms is needed. Another essential factor is the use of hot buffer between the casting machine and the furnace.

Hot buffer is used:

- to eliminate the effects of short stoppages in the rolling mill.

- to balance the production speed difference when rolling bars (the casting speed cannot be lowered to match the speed of the old rolling mill).
- for slow reheating of cold blooms at weekends and when appropriate.

For special steel grades a special quenching practice for blooms is used in some extend.

#### *Applicability*

The applicability is depending on the lay-out solution. The best way is to make the needed installations in connection with the investment.

#### *Environmental impacts*

The extremely high percentage of hot charging makes it possible, that the energy consumption, 0.94 GJ /t represents a good level. Taking into account, that the production practice is discontinuous. Typical values in European plants are between 1 and 2 GJ/h.

#### *Cross-media effects*

-

#### *Driving force for implementation*

- Reduced energy consumption.
- Reduced environmental impact.
- Efficient material flow, low bloom stock level.
- Increased productivity.

#### *Economics*

See point Driving force for implementation.

#### *Reference plant*

Ovako Imatra, Finland.

#### *Position in the present BREF*

Pos. II.A.4.1.3.1.7.

## **II/2**

### **Environmentally sound and energy efficient reheating of steel billets in a mini-mill reheating furnace**

#### *Description of the techniques*

Reheating of billets prior to hot rolling consumes a large amount of energy and creates emissions of greenhouse gases and other air pollutants. In many cases fossil fuels such as oil or natural gas is the energy source.

At Fundia Armeringsstål AS a major part of energy used in the reheating furnace is by-product gases, transported via pipelines, bought from neighbouring industrial companies. Electrical energy produced in hydro-power plants is the primary energy source for those companies.

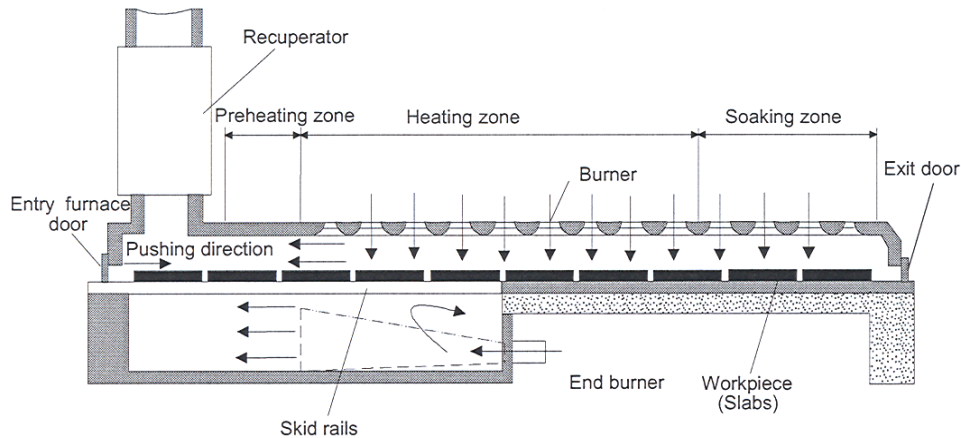

Figure 16. Pusher type furnace

The by-product gases used in the furnace is Hydrogen gas and Carbon monoxide gas. A small amount of low-sulphur (<0,05 % S) light oil is used to supplement energy input.

The annual percentage distribution ; H<sub>2</sub>-gas 42 %, CO-gas 42 %, oil 16 %.

The three fuels are burned in conventional combination burners and the flexibility of combining fuels in different ways in burners, burner zones and in the furnace are important to handle variations in necessary reheating capacity and variations in availability of by-product gases.

The reheating furnace is charged with hot billets to reduce energy consumption and thus reduce emissions. Special insulated transport equipment is developed and used to transport the billets by car from the steel plant to the rolling mill.

The practice belongs to “Established techniques”.

#### *Applicability*

The hot charging can be used whenever the distance from the steel plant to the rolling mill is not a practical prevention.

By-product gases can be used whenever such gases are technical and commercial available in the vicinity, and/or can be stored and transported in a safe and economical way.

#### *Environmental impacts and benefits*

Hot charging of billets reduces energy consumption and thus reduces emissions.

Use of industrial by-product gases, rather than fossil fuels, reduces emissions, and especially the high amount of Hydrogen gas has a substantial impact.

The energy consumption, approximately 1 GJ/t represents a top level in European reheating furnaces for billets. CO<sub>2</sub>-emissions are approximately 70 kg/t and dust emissions between 5-10 mg/t.

#### *Cross-media effects*

Main cross-media effect is using by-product gases from neighbouring industrial companies.

### *Driving force for implementation*

The driving force for implementation is environmental and economical.

### *Economics*

The by-product gases substitutes annually about 12 000 000 litres of oil consumption. The economics is depending on the price relations, but is positive anyway.

### *Reference plant*

Fundia Armeringsstål AS, Mo I Rana, Norway.

### *Position in the present BREF*

Pos. II.A.3.1.3.

## **II/3**

### **Mandrelless coilbox**

#### *Description of the techniques*

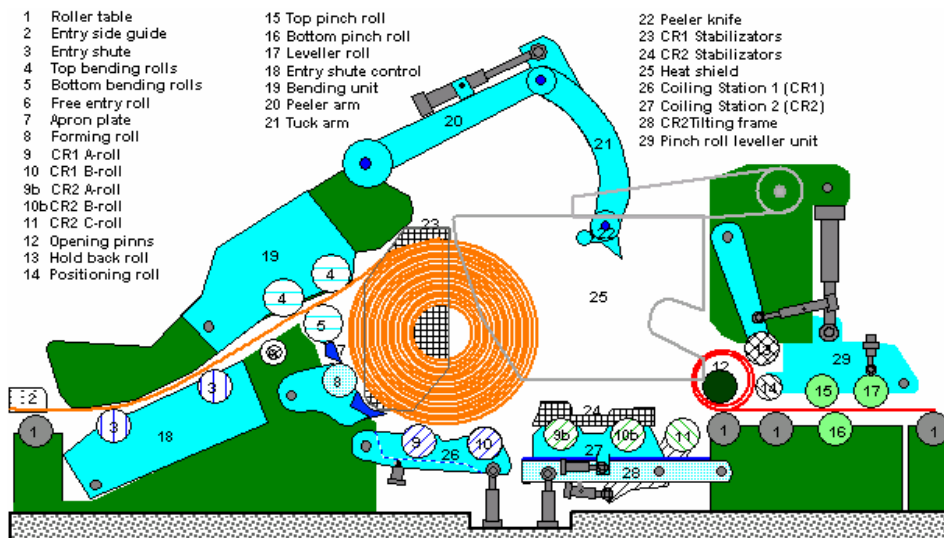

Figure 17. Coilbox principle layout

The intermediate product of roughing train (transfer bar) is wound up to a coil in a coilbox by means of electrically driven pinch/bending rolls and cradle rolls. After completion of coiling, the uncoiling will be started immediately by help of a peeler device. During uncoiling the coil will be transferred to an uncoiling station. In Mandrelless coilbox the transfer will be performed by tilting and shifting of cradle rolls instead of a transfer arm (“mandrel”) in the conventional coilbox. During the uncoiling and finishing rolling the coilbox is free to receive the next transfer bar. In this way, bottle necks in the production flow can be avoided.

Coilbox brings the advantage that the temperature distribution across the length of transfer bar remains constant and the loads during finishing rolling are reduced. Additional benefit of the Mandrelless version is that the inner wrap of coil is not in contact with the transfer arm which is the case in the conventional coilbox. Contact with the

transfer arm reduces significantly temperature of the tail end of the coil. The coilbox is also provided with heat shields to reflect heat radiation back to the coil. Heat shields are located aside of coil.

In the event of a cobble downstream of the rolling line, the coiled transfer bar maybe rollable for a longer period than would otherwise be possible. This measure improves the yield.

#### *Applicability*

Mandrelless coilbox is used at run-out table of new and existing hot rolling mills.

#### *Environmental impact and benefits, energy efficiency*

Main benefits of coilbox are reduced energy consumption and lower rolling power. By using coilbox can be achieved 40 % decrease in electrical peak power and 10 % drop in electrical energy consumption. Lower reheating/rolling temperatures can be used or product range (width to thickness ratio) may be widened, because of reduced heat losses between roughing and finishing areas.

Mandrelless coilbox reduces additionally heat losses of the inner wrap of coil decreasing risk of tail end pinching, which improves yield and mill availability. In coil eye can be achieved approximately 30-40 degrees higher temperatures with mandrelless coilbox. Tail end (coil eye) is normally coldest part of strip and therefore limiting factor considering needed temperature before and during rolling. By using mandrelless coilbox target reheating temperature for slabs can be decreased by 30 degrees which means approximately 3 % energy savings in furnace. This means 2.75 kg reduction in green house gases per produced ton steel.

#### *Cross-media effects*

More uniform product properties. More stable rolling process. Constant temperature before rolling enables constant rolling speed without acceleration and variation of process decreases. Adjustability of process is better.

#### *Driving force for implementation*

There is not enough space for long transfer bars between roughing mill and finishing mill. Coilbox enable full length slabs on thin transfer bars.

#### *Economics*

Coiling without transfer arm can be achieved 50 % reduction in temperature loss in the coil eye.

#### *Reference plant*

Ruukki Production, Raahe Works, Hot Strip Mill, Finland.

#### *Position in the present BREF*

Pos. II.A.4.1.7.1.

## II/4

### Oxy-fuel technology for heating operations

#### *Description of the techniques*

Oxy-Fuel technology is the general name for technologies where oxygen and fuel is used together in one or more burners to supply energy to a process.

Without nitrogen in the oxidant, more energy is available to the process at hand.

This leads to a number of important changes in the heating operation, such as: reduction of furnace gases, reduction of size of burners, filters and exhaust gas treatment equipment, and the increase of concentration of heat radiating gases ( $\text{CO}_2$  and  $\text{H}_2\text{O}$ ).

This in turn leads to other changes such as; possible increased flame temperature, possible decrease in  $\text{NO}_x$ -emission, increased heat transfer efficiency, reduced fuel consumption, reduced  $\text{CO}_2$ -emission, and possible increased productivity.

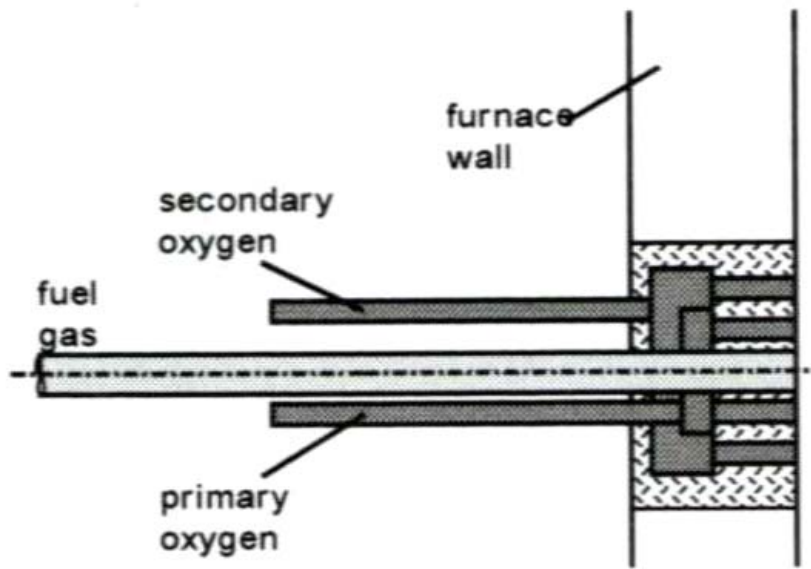

Figure 18. Oxy-fuel burner (800 kW)

#### *Applicability*

All furnaces where the heat treated material and the furnace is insensitive to a large increase in the water vapour concentration. Batch furnaces with high temperature ( $> 700\text{ }^\circ\text{C}$ ) processes are primary targets.

#### *Environmental impact and benefit*

Airtight furnaces have a large reduction of  $\text{NO}_x$  emissions, typically over 90 %; however, air leakage may cause large increase in  $\text{NO}_x$  emissions compared to standard low- $\text{NO}_x$  burners.

Energy savings of approximately 30 percent can be expected, without heat recovery equipment. If a life cycle analysis is made, the energy needed for the oxygen supply must be added.

### *Cross-media effects*

Reduction in fuel consumption. Increased consumption of O<sub>2</sub>. Reduction of exhaust gases. The total NH<sub>3</sub>-emission is significantly decreased because of low gas volumes even though momentarily a slight increase might occur.

### *Driving force for implementation*

Increased productivity in existing furnaces. Reduction of CO<sub>2</sub> and NO<sub>x</sub> emissions and reduced fuel consumption.

### *Economics*

Operating costs are related to oxygen price. High investment costs, but low maintenance costs. Typically the fuel savings match the oxygen costs. Possible decrease of environmental NO<sub>x</sub> and CO<sub>2</sub> tax costs.

### *Reference plants*

Outokumpu Stainless, Special products Nyby, Torshälla, Sweden.

Two annealing furnaces, LPG and Oil.

Outokumpu Stainless, Special products Avesta Works, Avesta, Sweden.

Annealing furnace, LPG.

Outokumpu Stainless, Special products Degerfors, Degerfors, Sweden.

Annealing furnace, LPG.

Batch furnaces, LPG.

Walking beam furnace, LPG.

### *Position in the present BREF*

Pos. II.A.4.1.3.6.

## **II/5**

### **Turbulence pickling for the continuous pickling line for carbon steel**

#### *Description of the techniques*

Pickling acid is sprayed on the strip surface with high pressure causing turbulent flow which breaks down the oxide layer.

#### *Applicability*

Can be applied also in existing lines.

#### *Environmental impact and benefits*

Amount of acid in the process is reduced by 57 %. HCl emissions/processed ton of steel into air are reduced by approximately 90 %. Investments which have positive influence on low HCL emissions are:

- Fume exhaust system.
- Scrubber and drop separator.

### *Cross-media effects*

-

### *Driving force for implementation*

Productivity. Environmental impact.

### *Economics*

-

### *Reference plant*

Ruukki Hämeenlinna Works, continuous pickling line, Finland.

### *Position in the present BREF*

Pos. II.A.4.2.2.5.

## **II/6**

### **Increased productivity through turbulent pickling**

#### *Description of the techniques*

Pickling of Stainless steel is, with some few exceptions, performed with a mixture of nitric and hydrofluoric acid (HNO<sub>3</sub>+HF). From beginning this was done by submerging the material in none turbulent baths. Modern or renovated pickling facilities are equipped with some kind of acid circulation system. The pickling speed and the capacity of the plant increases drastically due to the turbulence. The main reason for this is the supply of fresh pickling chemicals to the material surface at the same time as reacted acid is disposed from the surface.

Different types of turbulent pickling:

The most common system is the circulation through an external by-pass with the help of a strong pump. Acid is pumped from one side of the tank to the other therefore keeping the solution agitated.

The "turbo pickling" uses nozzles or ejectors on both sides of the tank to distribute the acid directly onto the material. The acid is pumped from the middle of the pickling tank over a circulation tank back to the nozzles to keep the solution agitated.

The "spray pickling" is most commonly used in the plate production. In this method acid from a separate circulation tank is sprayed onto the vertical standing plates. Ejector nozzles on both sides of the plate are used to distribute the acid. The pressure might vary depending on the installation.

#### *Applicability*

All new and existing plants.

#### *Environmental impact and benefits*

Reduction in acid consumption due to more effective chemical usage.

Reduction in waste from the pickling process due to more effective chemical usage.

High turbulence in the pickling bath increase the emissions of NO<sub>x</sub>. This can be reduced with existing reduction processes.

Typical emission figures are NO<sub>x</sub> 200 – 400 mg/Nm<sup>3</sup> and HF 5 mg/Nm<sup>3</sup>.

#### *Cross-media effects*

For comparison to a process without turbulence the following advantages in productivity were reported:

- Standard Stainless Steel can be pickled with up to 40 % shorter pickling time.
- Duplex Stainless Steel can be pickled with up to 20 % shorter pickling time.
- Special Stainless Steel can be pickled with up to 10 % shorter pickling time.

#### *Driving force for implementation*

Increased productivity.

#### *Reference plant*

By-pass circulation: Outokumpu Stainless, Coil products Nyby, Torshälla, Sweden.

Turbo Pickling: Outokumpu Stainless, Avesta Works, Avesta, Sweden.

Spray pickling: Outokumpu Stainless, Hot rolled plate, Degerfors, Sweden.

#### *Position in the present BREF*

Pos. II.A.3.2.2.

## **II/7**

### **SCR technology for NO<sub>x</sub> reduction in pickling line**

#### *Description of the techniques*

The Selective Catalytic Reduction (SCR) process is the most highly developed and widely used method for NO<sub>x</sub> removal from exhaust gases. The technique of Selective Catalytic Reduction can be applied to the emissions from mixed acid pickling. The process involves the reduction of NO and NO<sub>2</sub> to N<sub>2</sub> with ammonia (NH<sub>3</sub>) over a catalyst bed. The overall reactions are:

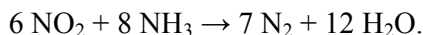
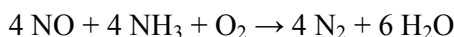

The optimum temperature for these reactions is 300-400 °C. Usually ammonia is added slightly sub-stoichiometrically (0.9-1.0 mole NH<sub>3</sub> per mole of NO<sub>x</sub>) to suppress carry-over.

Lime treatment can be used together with SCR for HF reduction. The gas flow is first heated and inserted into a reactor filled with CaO tiles where the HF of the gas reacts into CaF<sub>2</sub> according to reaction:

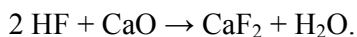

The most effective and widely used catalyst is vanadium pentoxide V<sub>2</sub>O<sub>5</sub>, supported on TiO<sub>2</sub>. Other substances exhibiting catalytic activity are Fe<sub>2</sub>O<sub>3</sub> and CuO; the noble metals (Pt, Pd, Ru, Rh); oxides of the metals W, Mo, Cr, Co and Ni; certain zeolites and activated carbon. The catalyst may be employed in a variety of structures and configurations to alleviate the problem of blockage by particulates depending on the severity of

the problem. A honeycomb shaped catalyst is suitable in a fixed bed configuration because it permits the particles to pass through without clogging. A moving bed configuration allows a deactivated or clogged catalyst to be constantly regenerated. A parallel-flow arrangement is also suitable.

Deactivation by poisoning (Na, K, As), erosion or solid contamination may limit the lifetime of the catalyst.

#### *Main achieved environmental benefits*

- Reduction of NO<sub>x</sub>.
- NO<sub>x</sub> reduction efficiency is typically 70-90 %. The efficiency of NO<sub>x</sub> reduction by SCR depends on the catalyst used and the initial NO<sub>x</sub> concentration.
- Reduction of HF emissions if coupled with lime treatment.

#### *Applicability*

New plants and major modernisation of existing plants.

#### *Cross-media effects*

- Energy consumption to heat exhaust gas to operating temperature for SCR.
- NH<sub>3</sub> consumption in the process.
- New CaO tiles every few years.

#### *Driving force for implementation*

Minimization of NO<sub>x</sub> emissions, environmental protection.

#### *Economics*

Relatively high capital cost and therefore suitable only for large installations.

#### *Reference plants*

Four units in Outokumpu Stainless Tornio plant, Finland: annealing and pickling lines 1+2 (joint unit), annealing and pickling line 3, annealing and pickling line 4 and rolling, annealing and pickling line 5 (RAP5).

#### *Position in the present BREF*

Pos. II.A.4.2.21, II.D.2.4.

## **II/8**

### **NO<sub>x</sub> suppression by injection of Hydrogen peroxide (H<sub>2</sub>O<sub>2</sub>)**

#### *Description of the techniques*

In pickling of stainless steel, the nitric acid reacts with the metal or metal oxide and is reduced to nitrous acid (HNO<sub>2</sub>), which is in equilibrium with a mixture of nitrogen oxides.

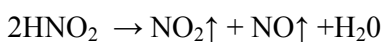

The nitrogen oxides NO<sub>x</sub> are not very soluble in water and would ultimately be emitted from the process. The presence of H<sub>2</sub>O<sub>2</sub> rapidly oxidizes the HNO<sub>2</sub> to the more stable HNO<sub>3</sub>, thus preventing the emissions of NO<sub>x</sub>.

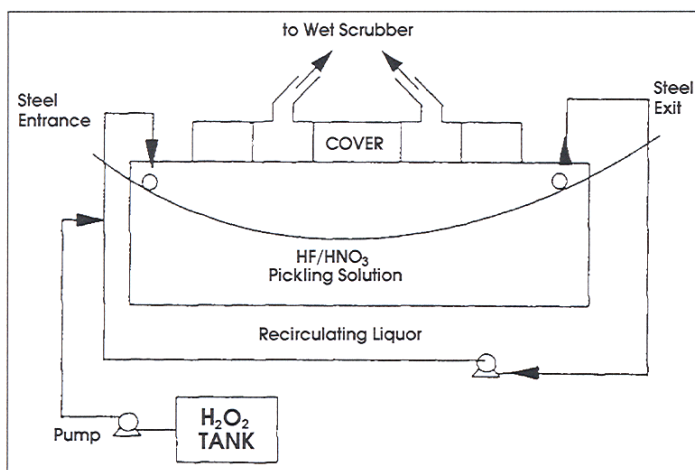
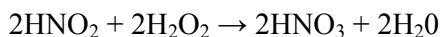

Figur 19. Schematic for injecting  $\text{H}_2\text{O}_2$  into pickling acid recirculation loop (WireInd-10-97)

#### *Applicability*

All new and existing plants using mixed acid in the pickling operation.

#### *Environmental impact and benefits*

Reduction of  $\text{NO}_x$  reduction efficiency is typically 70-90 %. Reduction rates of over 90 % have been reported. The key to efficient usage of hydrogen peroxide for  $\text{NO}_x$  suppression, by addition to the pickling tank lies in effective mixing.

The reforming of  $\text{HNO}_3$  are the main benefits of this process. Due to the reforming of  $\text{HNO}_3$  it is possible to reduce the consumption of nitric acid by up to 25 %.

The process is energy efficient compared to the catalytic technologies because the hydrogen peroxide system does not require heating of waste gases. Energy usage is only related to pump capacity for the injection of  $\text{H}_2\text{O}_2$ .

#### *Cross-media effects*

Reduction in acid consumption.

Consumption of hydrogen peroxide (4-6 kg (35 %) per ton material). There are very strict safety instruction when using  $\text{H}_2\text{O}_2$ .

#### *Driving force for implementation*

Reduction of  $\text{NO}_x$  emissions.

#### *Economics*

Low investment costs compared to catalytic systems. Operational costs are related to the consumption of hydrogen peroxide (4-6 kg (35 %) per ton material).

#### *Reference plant*

Outokumpu Stainless, Coil products Nyby, Torshälla, Sweden.

*Position in the present BREF*

Pos. II.A.4.2.2.20, II.D.5.8.1.

## II/9

### **OSAR - Outokumpu Sulphur dioxide Aided chromium Reduction**

#### *Description of the techniques*

In this process, the strip rinsing waters from electrolytic pickling and the solids from electrolytic pickling bath are treated to reduce their hexavalent chromium ( $\text{Cr}^{6+}$ ) concentration. They are first stored in a mixing tank to level concentration differences of different feed streams. Sulphuric acid is fed into mixing tank to lower the pH value of the solution. Low pH value increases the rate of reduction reaction. The chemical reactions also consume sulphuric acid so it must be fed into the mixing tank before the actual reduction reactions take place.

After mixing the solution is pumped into feeding tank. It is also possible to control the pH value of the solution at this point. From the feeding tank the solution is pumped into reduction reactor 1 and from there the solution goes to reduction reactor 2 by means of overflow. There are two reactors in series.

Liquid sulphur dioxide ( $\text{SO}_2$ ) is fed into both reactors. The reduction reaction is:

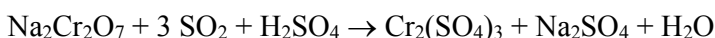

The reduction of  $\text{Cr}^{6+}$  is monitored through pH and redox-potential values. An automated analyser analyses the  $\text{Cr}^{6+}$  concentration of solution in the feeding tank and adjusts the feeding of sulphur dioxide accordingly. The controller also uses the feed rate and the redox-potential value as inputs for the calculation of required  $\text{SO}_2$  addition.

After the reduction process the solution is fed into neutralization process together with acidic rinsing waters from the mixed acid pickling.

Main achieved environmental benefit:

- Reduction of  $\text{Cr}^{6+}$  emissions to water, in practice close to zero.

#### *Applicability*

New and existing plants.

#### *Cross-media effects*

- Consumption of sulphur dioxide.
- Consumption of sulphuric acid.

#### *Driving force for implementation*

Minimization of  $\text{Cr}^{6+}$  emissions to water.

#### *Economics*

Sulphur dioxide is more effective reducing agent than widely used sodium metabisulphate ( $\text{Na}_2\text{S}_2\text{O}_5$ ). That leads to smaller reactor sizes and decreases investment costs.

#### *Reference plants*

Outokumpu Stainless Tornio, Neutralization plant 2, Finland.

*Position in the present BREF*

(Pos. II.A.3.2.2.)

## II/10

### **OPAR - Outokumpu Pickling Acid Recovery System**

*Description of the techniques*

In this evaporation process, the spent pickling acid containing hydrofluoric acid (HF) and nitric acid (HNO<sub>3</sub>) is concentrated together with sulphuric acid at 90 °C under vacuum to drive off HF and HNO<sub>3</sub> which are condensed and recycled. The precipitated metal salt is neutralized.

The spent pickling acid is fed into a vacuum evaporator together with circulating sulphuric acid. In the vacuum evaporator the mixed acid is heated to about 90 °C. Make-up sulphuric acid is added to such extent that the concentration of at least 60 % is reached. This concentration ensures high yield of recovered pickling acids. Metal fluorides and nitrates form metal sulphates and liberated acid. These reaction products build up according to the following reactions:

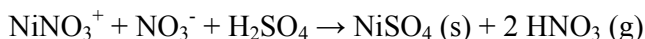
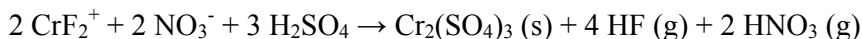
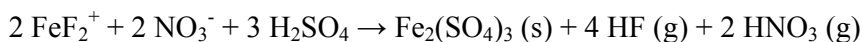
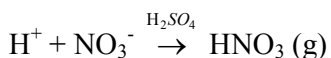
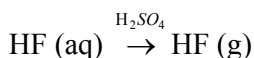

The water, HF and HNO<sub>3</sub> are vaporized and condensed. The overflow of the condenser is led to the product acid tank. The overflow of the evaporator is led to the crystallizer tank. The evaporator overflow consists of the recently formed metal sulphates and sulphuric acid.

The metals form sulphate chain complexes in the strong sulphuric acid solution, which cause incomplete crystallization of the metal sulphates. These complexes are decomposed by raising both the temperature and the H<sub>2</sub>SO<sub>4</sub> concentration, which leads to the precipitation of metals and to evaporation of acid (HF and HNO<sub>3</sub>) residues. This heat treatment occurs in a submerged combustion evaporator. The combustion gases are ducted down below the acid liquor surface through a dip tube. The sulphuric acid concentration of 80 % is reached at 150 °C. The underflow of the submerged combustion evaporator is led to the crystallizer tank. The combustion gases are washed in two steps to recover HF and HNO<sub>3</sub> acids from the gas. First the gas is washed using a venturi scrubber. There is also a general gas scrubber included in the regeneration process. Gases from the venturi scrubber, from crystallization and from other process steps are all washed. The acid solution washed from the gases is combined with the product acid from the evaporation and condensing part of the process.

Long enough residence time in the evaporation-crystallization circuit also improves the filtering properties of the sulphate salt formed. The sulphate slurry from the crystallizer

tank is pumped to the cone thickener. The underflow of the thickener is led to the press filter to separate metal sulphates from the acid liquor. The filtrate is returned to the crystallizer. The metal sulphate cake from the press filter is neutralized in a separate process.

The process equipment has to be constructed by using high quality materials. Special corrosion resistant steels and fluorocarbon polymers are extensively used as construction materials for the process equipment. The process is presented in Figure 20.

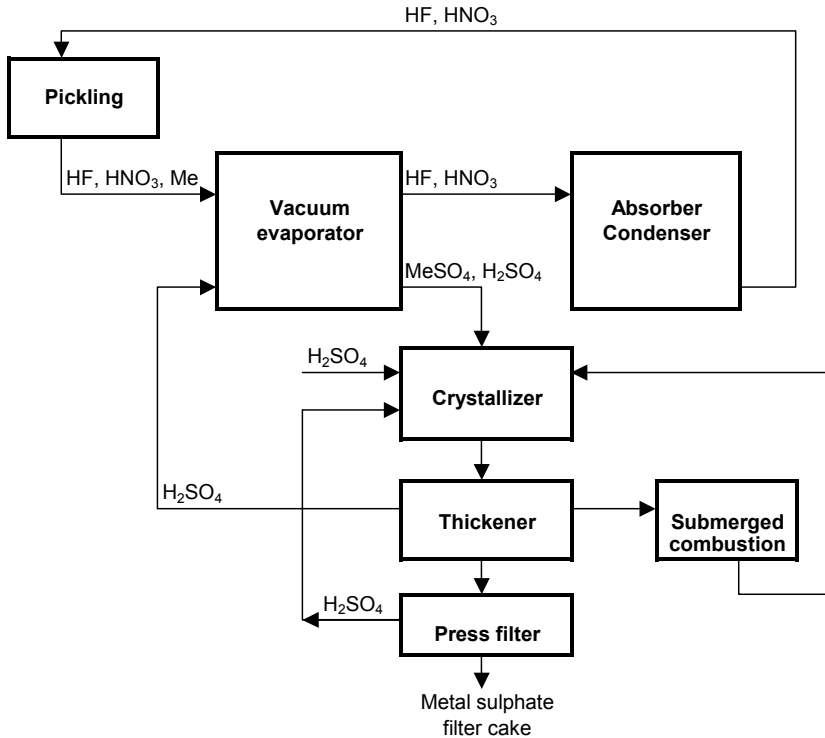

Figure 20. The OPAR evaporation process for mixed acid regeneration.

- Main achieved environmental benefits: Reduction of fresh acid consumption by recycling both free and bounded  $\text{HNO}_3$  and HF.
- No nitrates in waste waters.
- No dust emissions.

*Applicability*

New and existing plants.

*Cross-media effects*

- Consumption of energy to evaporate acids.
- Consumption of sulphuric acid.
- Generation of metal sulphates, which can be neutralized to metal hydroxides.

*Driving force for implementation*

Total regeneration of acids.

### *Economics*

- Savings due to reduced consumption of fresh acids.
- Easy to maintain constant composition of pickling acids.
- No need for acid neutralization. High investment cost.

### *Reference plants*

Three units in Outokumpu Stainless Tornio plant, Finland:

- Regeneration plant 1, capacity 1.5 m<sup>3</sup>/h, year of start 1984.
- Regeneration plant 2, capacity 3.0 m<sup>3</sup>/h, year of start 1997.
- Regeneration plant 3, capacity 6.0 m<sup>3</sup>/h, year of start 2003.

### *Position in the present BREF*

Pos. II.A.3.2.3.

## II/11

### **Acid recycling by electrodialysis**

#### *Description of the techniques*

Electrodialysis (ED) is a membrane filtration process, which with the help of ion selective membranes and an electric field is able to recycle acid, mainly nitric acid, from a waste acid stream and concentrate the recycled acid to a concentration reusable in the pickling process.

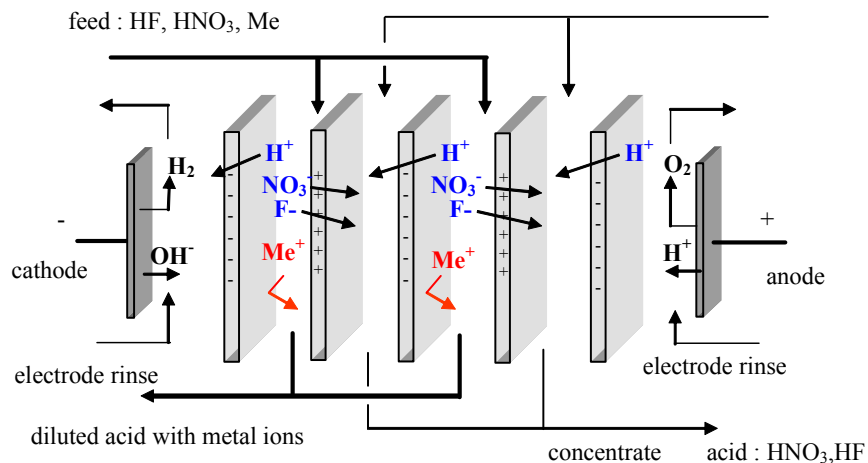

Figure 21. Acid recycling by electrolysis

The main advantage of the ED system is the fact that the process can not just separate ionic acid and metals but concentrate the product to a reusable concentration. Due to the chemical state, fluoride lies mainly in un-polarised form as HF or MeF. The electric field therefore has no effect and the recycling rate for HF is low.

The free HNO<sub>3</sub> recovery rate can exceed 90 %, the metal separation exceeds 95 %.

### *Applicability*

The process can work on variety of waste acids too low concentrated for direct reusage e.g. by-products from acid retardation or diffusion dialysis.

The process is appropriate for new and existing plant and is not limited just to the mixed acid pickling systems.

### *Environmental impact and benefits*

Reduction of Nitrates to water. The installation of the reference plant has let to a total output reduction of Nitrates with 55 %. The consumption of fresh acid has reduced accordingly, minimizing also acid production, handling and transport.

Energy consumption: 1-2 KWh/kg HNO<sub>3</sub>.

### *Cross-media effects*

- Reduction of fresh acid consumption.
- Reduction of waste products to be deposited on landfill.
- Reduction of neutralisation chemicals (Lime).

### *Driving force for implementation*

Reduction of Nitrate discharge.

### *Economics*

Savings in acid, neutralisation chemicals and landfill costs are expected to be higher than the operational costs.

Energy consumption: 1-2 KWh/kg HNO<sub>3</sub>.

### *Reference plant*

Outokumpu Stainless, Coil products, Nyby, Torshälla, Sweden.

### *Position in the present BREF*

Pos. II.A.4.2.2.1.

## **II/12 - Nordic hot dip (batch) galvanizing**

### II/12.1

#### **Hot dip galvanizing at JIWE**

##### *Description of techniques*

Hot dip galvanizing plants are mostly manually operated. The JIWE plants in Sölvesborg are highly automated where hanging on and hooking off of components are the only manual operations that exist.

Normally hot dip galvanizing plants are noisy and smoky working places with problems to live up to modern environmental standards. The new JIWE plant is a warm and low-noise working place with no fumes of any kind in the working atmosphere.

The exhaust gases from the zinc kettles and from the pre-treatment tanks are taken through a wet scrubbing system where flux and metal oxide particles as well as acid fumes are removed. The particles are reduced from 20-30 g/Nm<sup>3</sup> dry gas to below 5 g/Nm<sup>3</sup> and the acid fumes from 10 g/Nm<sup>3</sup> to below 0.01 g/Nm<sup>3</sup>.

The gases are then passed through a heat exchanger where heat is recovered for warming of the working air of the large premises. The sludge from the scrubbers is pumped to the water purification plant for further treatment.

All rinsing waters from the pre-treatment of the galvanizing goods as well as the sludge mentioned above are treated in a water purification plant. The purification is made by efficient precipitation of metals, predominantly zinc. The metal contents after this treatment lie well below the limits set by the environmental authorities. For instance, the zinc content after the purification plant is approximately 0.2 mg/l compared to the limit set by the authorities of 1.0 mg/l. Next year a reversed osmosis plant will be installed that will make it possible to completely close the processes on the water side. The only waste from the plant will then be metal hydroxide containing filter cakes that are transported to a central dump controlled by the government.

#### *Applicability*

The technique can be used in all hot dip galvanizing plants where long series of medium weight goods are being treated.

#### *Environmental impacts and benefits, energy efficiency*

The environmental impact of hot dip galvanizing is minimized. The heat recovery from the exhaust gases makes it possible to keep the working air at 18 °C down to an outdoor temperature of -14 °C. Down to that temperature no oil or electricity need to be used for heating of the working air. Several environmental figures are described in the previous chapter.

#### *Cross-media effects*

Lower absence due to illness among workers.

#### *Driving force for implementation*

Increased productivity. Healthier personnel. Lower production costs. Reduced environmental impact.

#### *Economics*

All four items above give better profitability and company good will.

#### *Reference plant*

JIWE Varmförzinkning, Sölvesborg, Sweden.

#### *Position in the present BREF*

Pos. II.C.3.

II/12.2

### **The pre-treatment process at hot dip galvanizing**

### *Description on techniques*

Hot dip galvanizing is the most efficient form for protection against corrosion. As steel is a more precious metal than zinc, zinc will protect steel cathodically. During the hot-dip galvanizing process where the material is dipped into a zinc molten of approximately 450 °C, the two metals react in such a way that an alloy is created between the metals, ensuring an extremely strong adhesion between zinc and steel.

This alloy is so strong that the steel construction can be transported and handled without damaging the zinc.

Hot dip galvanized steel is maintenance-free.

After a pre-treatment the steel construction is lowered into the zinc melt. In case of any excess zinc, this is subsequently removed from the steel construction and the quality of the construction checked in order to achieve the best possible result. The following gives a description of the pre-treatment.

#### Pre-treatment

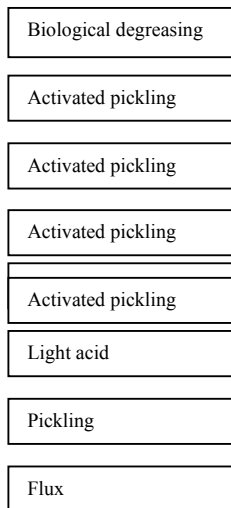

After the biological degreasing the items are directly lowered into the activated pickling bath with 4-6 % acid and a iron content of 120-180 g/l. The items are hung up with black steel wires that are only used once in order to avoid that zinc coated wires are lowered into the pickling bath again. Furthermore is zinc from items that are galvanized removed in a special pickling acid (1-2 % acid). In this way the concentration of zinc in the activated pickling bath can be kept at a low level.

There are 5 pickling baths each of 30 m<sup>3</sup>. From each of these baths 10 m<sup>3</sup>/h acid is circulated by means of a pump. This circulated acid is alloyed and lead through a heat exchanger before it is lead back to each of the baths by a distribution system. In this way both the heating and circulation in the baths are managed.

It is important not to rinse between the two processes, biological degreasing and pickling, as the chemicals from the degreaser act as inhibitors in the pickling bath and in that way prevents acid corrosion on the parent metal.

After treatment in the pickling bath the items are rinsed in a light acid bath in order to dilute the pickling bath when part of this is discarded. The light acid has a typical iron content of 30-40 g/l that gives a large reduction of the iron content in the flux bath.

The flux bath is successively purified for iron by a sediment separator and filter press. The smoke from the kettle and pre-treatment is lead through a water scrubber in order to purify the gas before getting it discharged into the open.

#### *Applicability*

All hot dip galvanizers can apply the technique.

#### *Environmental impact and benefit*

The pre-treatment process is based on cleaner technology, which is achieved through a minimal consumption of resources as well as influence on the internal and external environment. The waste fractions are as follows:

- Sediment from the biological degreaser that is dehydrated at an external purifying plant.
- The discharged pickling bath is delivered to a company that uses it as a precipitant at the purifying plant.
- The discharged pickling acid is used in the flux, which is pH-controlled with ammoniac. In this manner flux salts are generated and you save on adding more of these. A sediment separator and filter press successively purifies the flux. The filter cake from here is recycled.

#### *Cross media effects*

A more uniform product quality is ensured as the pre-treatment is taken place under constant conditions.

#### *Driving force for implementation*

- Savings on raw material and waste reduction.
- Larger production.
- Trustworthy pre-treatment.
- Reduction of emission.

#### *Economics*

The technology results in less consumption of raw materials as well as reduction of waste.

#### *Reference plant*

DOT in Køge.

#### *Position in the present BREF*

Pos. II.C.4.2.4, II.C.4.3.3.

II/12.3

**Powder coating of hot-dip-galvanized (HDG) steel products.**

### *Description of the techniques*

The powder coating plant has 2 seven steps zinc-phosphating processes prior to the powder application. One spray line for products smaller than 6 m in length and one immerse line for longer products. Waste rinsing water and chemicals are neutralised and cleaned. Almost 100 % of waste powder (spray material) can be recycled. There are two drying kilns in the process line. One after pre-treatment and the other for powder hardening on the surface.

### *Applicability*

The process can operate products up to 12 m x 0.6 m x 1.5 m (l x w x h) and weight up to 1000 kg.

### *Environmental impacts and benefits, energy efficiency*

Powder coating of HDG steel products has a synergetic effect on length of life of the duplex coating and equal to the products. In addition the colour gives an aesthetic environmentally friendly effect.

The coating powder is entirely free from solvents and can be applied to the products with less waste than any other painting process.

Powder coating is the most energy-efficient and environmentally friendly alternative that exists to provide zinc coating with added protection and colouring. The energy consumption is reduced with about 50 % compared to wet coating. The material yield is very high (>95 %).

### *Cross media effects*

The powder coating will reduce possible zinc run-off from products to the environment.

### *Driving force for implementation*

Cost reductions. Increased corrosion protection and aesthetics of products. New product and market possibilities.

### *Economy*

Reduced costs and increase in turnover due to new products and markets have improved the profitability.

### *Reference plant*

Ørsta Stål AS in Norway.

### *Position in the present BREF*

Pos. II.C.2.10.

II/12.4

## **Filtration of gases/fumes from hot dip galvanizing bath**

### *Description on techniques*

- Gases/fumes from hot dip galvanizing bath will be sucked from hood to bag filter.
- Bag filter is situated outdoors.

- Bag filter should be isolated 100 mm and the hopper should be heated. Arching problems in the hopper can be prevented.
- The filter material should be Gore-Pristyne-membrane laminated to polypropylene-felt.
- The control system of the cleaning automatism consists of a differential pressure switch and a timer, which enable the cleaning of filter elements by means of the differential pressure of the filter. This means that if there is no need for cleaning (there is no dust cake on the filter elements) no unnecessary cleaning takes place.
- From bag filter cleaned gas can be recirculated back to production premises. Emission level after bag filter should be  $< 3 \text{ mg/m}^3$ , measured values have been 0.1-0.3  $\text{mg/m}^3$ .
- The fan is controlled by frequency converter.
- Normally airflow is 50 % from max airflow and when dipping is on progress airflow is 100 %.
- Because this dust is very sticky and very sensitive for moisture there should be talcum injection before bag filter. Problems with high  $\Delta p$  can be prevented and longer service time for filter bags (normally 3-4 years) can be achieved.

#### *Applicability*

- Bag filters have been used in hot dip galvanizing plants many years, but there have been problems with high  $\Delta p$ , high emission level and very short service time for filter bags. To high emission level after filter unit means that gases can't be recirculated back to production premises and all warm gases can't be driven out.
- With this kind of filter unit emissions after filter can be minimized,  $\Delta p$  lowered, and longer service time for filter bags achieved.
- More than 10 filters for hot dip galvanizing plants have been installed in Finland.

#### *Environmental impact and benefits + energy efficiency*

- Cleaned gas can be recirculated back to production premises 100 %.
  - Gas temperature is 40-60 °C.
  - Energy from cleaned gas can be recovered.
  - Incoming air does not need to be heated.
  - Air balance in production premises will be steady. No need to arrange compensation air to production premises.
- Lower  $\Delta p$  over filter bags.
  - Lower  $\Delta p$  over filter bags means lower energy consumption.
  - 50 % lower  $\Delta p$  gives 50 % reduction of energy consumption.
- Lower emission level after bag filter.
  - Emission level after bag filter is  $< 3 \text{ mg/m}^3$ , measured values after 1-2 years using have been 0.1-0.3  $\text{mg/m}^3$ .

- In summertime the gases are normally not recirculated gases back to production premises. Environmental impacts are remarkable.

*Cross media effects*

- Working conditions are much better, because air is cleaner in production premises.
- Because cleaned air can be recirculated back to production premises, there is no need to arrange compensation air.

*Driving force for implementation*

- Environmental laws.
- Improvement of working conditions.

*Economics*

- Because cleaned air can be recirculated back to production premises, there is no need to arrange compensation air.
- Lower  $\Delta p$  over filter bags means lower energy costs.

*Reference Plant*

- Galvanoimis Oy, Finland.
- 2 filter units for gases/fumes from hot dip galvanizing bath.

*Position in the present BREF*

Pos. II.C.4.6.

## **II/13**

### **Roll coater in passivation of hot dip galvanized strip**

*Description of the techniques*

Roll coater can be used instead of dip/squeeze or spray/squeeze methods for the passivation of strip. Especially thin organic coatings (TOC) or anti-finger print coatings (AFP) are applied by roll coater.

*Applicability*

New and existing plants. For existing plants available space might be a limiting factor.

*Environmental impact and benefits*

Better passivation film thickness control reduces passivation chemical consumption. The amount of zinc dissolved into the passivation solution is estimated to reduce about 90 % compared to dip/squeeze or spray/squeeze methods because of very short contact time between chemical and the strip.

*Cross-media effects*

-

*Driving force for implementation*

Productivity and environmental impact.

*Economics*

Relatively expensive equipment.

*Reference plant*

Ruukki Hämeenlinna Works, galvanizing line #3, Finland.

*Position in the present BREF*

Pos. II.B.6.1.1.

*Objects in the BREF II - (Emerging techniques)*

**II/1E**

**Endless rolling practice for demanding wire rod -products**

*Description of the techniques*

The endless rolling system is a system for welding together subsequent billets in hot state in the wire rod mill line to produce an endless rolling process.

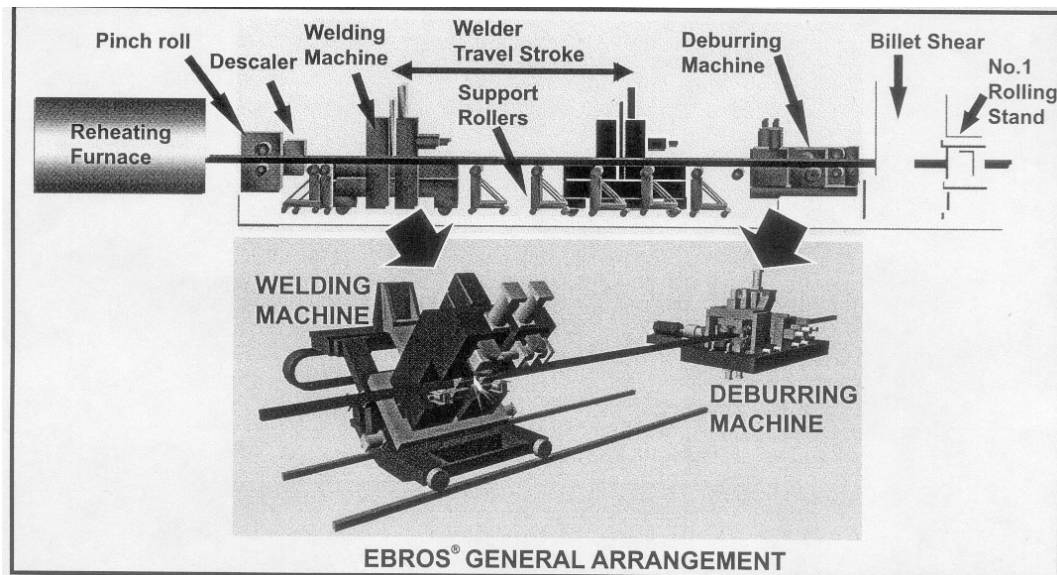

Figure 22. Endless rolling

Welding is done by the flash welding method. The properties of the welded joint after rolling are equal to those of the parent material. The joint in saleable product, concerning also demanding steel grades.

The endlessly rolled wire rod -product is cut to customer-specified coil weights after the cooling conveyor.

The technology belongs to “Emerging techniques”.

*Applicability*

The endless rolling system is applicable both to new and existing wire rod mills, depending on the lay-out.

*Environmental impacts and benefits, energy efficiency*

A potential for yield improvement by 2-3 %-units.

*Cross-media effects*

-

*Driving force for implementation*

Customer-specified coil weights. Bigger coils in weight.

*Economics*

-

*Reference plant*

Ovako Dalsbruk, Finland.

*Position in the present BREF*

Pos. II.A.6.1.4.1.

## **II/2E**

### **Sequential impulse firing burner technology in the reheating furnace in the hot strip mill**

*Description of the techniques*

Burner operates always at nominal gas flow and power of the burner is adjusted between 10 to 100 % by the firing time of the burner: a heat demand of 40 % means burner is firing for 40 % of the 60 seconds cycle. All the burners are connected to air and gas main headers and level 1 automation controls pressure in each header. Constant and minimized air excess of the furnace is set with the pressure in the air header and for a zone a different air excess is set with ratio between opening times of air and gas shut-off valves at the burner.

Time-based burner control decouples flame profile from heat demand. Slab temperature uniformity is improved because heat is brought homogeneously into the whole furnace width in every production condition.

Each sequential burner pair in opposite sides of the furnace can be considered as a zone. It improves flexibility of the heating process and heating can be done more accurately with lower energy consumption.

The technology belongs to the list "Emerging techniques".

*Applicability*

Technique is mainly for new reheating furnaces because of the need of big air and gas headers. Modifications of furnace bottom zones to pulse firing technology have been done.

*Environmental impact and benefits, energy efficiency*

Reduced emissions with good combustion efficiency: Ultra-low- NO<sub>x</sub> -burners are always functioning in nominal conditions build for minimal NO<sub>x</sub> -formation. Data will be available during September 2005.

### *Cross-media effects*

Improved heating quality affects positively on product quality.

### *Driving force for implementation*

Heating quality, more flexibility for processing of small batches of different products, furnace performance (energy, NO<sub>x</sub>).

### *Economics*

The economical benefit at the furnace will be low energy consumption. It results from the furnace itself and heating control done by heating optimisation system.

### *Reference plant*

Ruukki production, Raahe Works, Finland.

Walking beam furnace 5, with sequential burners in all bottom zones and top preheating and heating<sup>1</sup> zones, roof burners in top heating<sup>2</sup> and top soaking zones, will be commissioned in April 2005.

### *Position in the present BREF*

Pos. II.A.6, II.A.4.1.3.2.

## **II/3E**

### **Processing of hydroxide sludge from stainless steel pickling to a usable slag former in the melting shop**

#### *Description of the techniques*

The process utilises the hydroxide sludge which today is to 100 % deposited on landfill. With a heat treatment the water, free water as well as crystalline water, is evaporated. Then the material is calcinated/sintered at about 1000 °C to a mechanically stable product, which has got a working title hydroflux. The strength of the hydroflux product is almost as high as that of ordinary fluorspar and then it can be added according to established procedures in the melt shop.

About 40 full scale trials at Avesta Works during 2004 have been performed and they show that hydroflux, containing about 45-55 % CaF<sub>2</sub>, works as well as ordinary fluorspar, with about 90 % CaF<sub>2</sub>, as a slag former in the AOD converter regarding obtained slag properties. Any deviations in effects on the final stainless steel product have not been found.

About 15 000 tons of hydroxide sludge are produced by the Swedish production units of Outokumpu per year. In calcinated form this contains about 3 500 tons of CaF<sub>2</sub>. The AOD converter needs about 6 000 tonnes fluorspar per year and will be able to use all the yearly produced hydroflux, either as substitute or in combination with ordinary fluorspar.



residues. Hydroxide sludge is one type of a metallurgical residue and it is a good example that the authorities have pushed the industry to develop alternative methods to take care of the by-products produced by the pickling processes.

#### *Economics*

The economic value of the deposited hydroxide sludge is about 2 500 € per tonne. The yearly consumption of CaF<sub>2</sub> in the AOD process is higher than the amount of deposited hydroxide sludge. This means there are good chances to close all hydroxide landfill sites in Sweden within a couple of years.

#### *Reference plant*

A reference plant is likely to be build at Outokumpu's Avesta Works in Sweden.

#### *Position in the present BREF*

Pos. II.A.6, II.A.4.2.

## **II/4E**

### **Passivation with Cr<sup>6+</sup>-free products in the continuous hot dip galvanizing line**

#### *Description of the techniques*

Chromate, Cr<sup>6+</sup>, in passivation chemicals for white rust prevention of hot dip galvanised strip will be replaced by Cr<sup>3+</sup> or other inorganic element such as Si, Ti, Zr, Mn, Mo. The preventive layer can be reactively formed film applied with thickness of << 1 µm or thin organic coating TOC with thickness of 1-2 µm. Some full scale production trials have been done.

#### *Applicability*

In many cases Cr<sup>6+</sup> free passivation can be applied with the same line equipment used for chromate passivation. However roll coater or spray/squeeze methods are preferred.

#### *Environmental impact and benefits*

Very important environmental impact because of carcinogenic nature of Cr<sup>6+</sup>. Clear benefit for working conditions and waste handling.

#### *Cross-media effects*

Corrosion prevention properties of Cr<sup>6+</sup> free passivations might not reach the level of Cr<sup>6+</sup> systems.

#### *Driving force for implementation*

EU directives ELV (End of Life Vehicle) and WEEE (Waste of Electronic and Electrical Equipment). ELV bans the use of hexavalent chromium in corrosion preventive coatings in new vehicles from July 1, 2007. According to WEEE from July 1, 2006 hexavalent chromium in electrical and electronic equipment must be replaced.

#### *Economics*

Increased production costs because of higher chemical price and because of the need to replace Cr<sup>6+</sup> contaminated rolls, tanks, tubing etc. in passivation unit.

*Reference plant*

Ruukki Hämeenlinna Works, galvanizing line #3, Finland.

*Position in the present BREF*

Pos. II.B.6.1.3.

**II/5E**

**Advanced SCR-application for NO<sub>x</sub> reduction in the annealing line**

*Description of the techniques*

Waste gases from LPG burners in the heating furnace in the continuous annealing line are passed through a SCR plant to reduce the NO<sub>x</sub> content. The flow rate, temperature and NO<sub>x</sub> content in the waste gases is depending on the strips produced and change very fast.

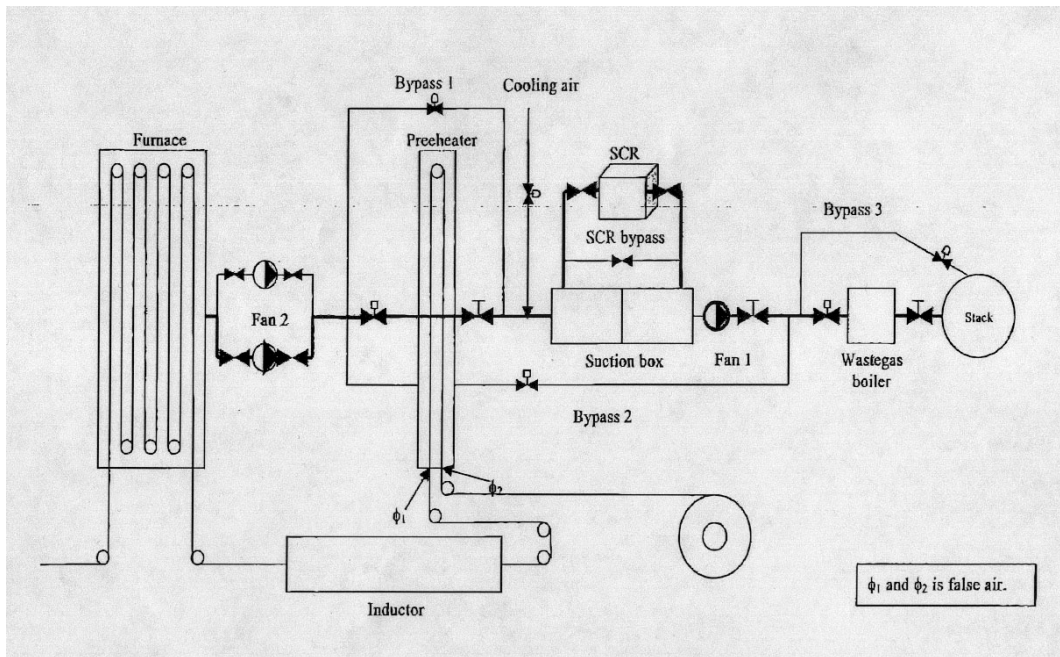
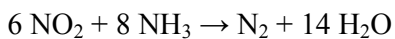
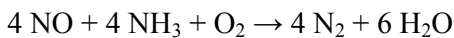

Figure 24. SCR in annealing line

Before the waste gases reach the SCR plant, they pass a preheating furnace where the hot gases heat up the incoming cold strip. Any oil on the strip will evaporate and go with the waste gases through the SCR plant.

The reaction is taken place in two catalyst layers in a reactor where evaporated 25 % NH<sub>3</sub> solution is injected in the waste gases at temperatures between 160 and 400 °C.



The NO<sub>2</sub> content is 2-3 %.

### *Applicability*

The process is applicable in waste gases system containing NO<sub>x</sub>. The process requires clean gases with respect to dust, SO<sub>3</sub>, oil and metals, eg. As and Pb.

### *Environmental impacts and benefits*

During the first year in operation the NO<sub>x</sub> content was reduced by 75 % from a level of 130 ppm and the total removal of NO<sub>x</sub> correspond to 50 tonnes per year.

### *Cross-media effects*

Interaction between actual emittent of NO<sub>x</sub> and other sources in the steel plant.

### *Driving force for implementation*

Decision by the Swedish Environmental Court judged on an application for increased production.

### *Economics*

Total estimated cost for the NO<sub>x</sub> reduction is about 10 €/kg NO<sub>x</sub>.

### *Reference plant*

SSAB Tunnbrått AB, Borlänge, cold rolling mill, Sweden.

### *Position in the present BREF*

Pos. II.D.2.4.



# Evaluation of the selected objects from the BAT point of view

The basic idea when working out this document was to find out good Nordic examples, examples which according to our own and other Nordic expertise are representing a good BAT level. In practice it means, that the objects (good examples) in this document all belong to the “group of the best in the European class”. It is absolutely impossible to use the impression “the best in Europe”, and that has also been avoided. In some cases, as a very good example: “Nordic blast furnace practice”, it can be established, that these practices represent the absolutely top level in Europe (and in the world) in BAT meaning.

In this project we could find out several synergies between the Nordic processes and practices (for example Nordic district heating and pickling), which gave the possibility for comparison of these objects and at the same time gave added value for the whole project.

Numeric data is important when evaluating the environmental impacts and benefits.

In the objects of “Established techniques” the available data is generally included. On the other hand, in the objects of “Emerging techniques” there are naturally lack of data in most cases.

As a result, there are totally 35 objects of which 3 are collective objects with 3, 4 and 12 sub-objects. 8 objects belong to the “Emerging techniques”, which is considered to be a suitable proportion, taking in account that the most of them are under realizing.

The examples represent processes, sub-processes, measuring technologies etc. The common availability of them is good, although some objects are at least partly depending on local circumstances.

Some further notices:

- Reduction in CO<sub>2</sub> emissions is frequently observed in the selected objects.
- A lot of attention has been focused on the reduction of harmful gases (for example NO<sub>x</sub>).
- There are examples of BAT practices with good results without expensive facilities.
- Utilization of slags has been noticed both as “Established-” and as “Emerging technique”.
- Energy efficiency has in many examples been connected with the environmental impact.
- Also service of the equipment (for example filters) has been taken as a good BAT example.

- The driving forces for implementation have in most of the objects been environmental impacts or energy efficiency coupled with environmental impact. Increased productivity including some environmental impact has been driving force in some objects.
- The economics has in many objects been calculated, but in several cases economic data is classified information. In a couple of objects there is some increase of cost coming from environmental improvements.

# Conclusions

In this project totally 35 objects (grand total 51 individual objects) have been selected to be good Nordic examples of BAT level. The objects are well covering both BREF's (2001) in question.

- The project was worked out in a tight time schedule (5 months) including two intermediate reportings. The co-working with the representatives of the industry was working very well.
- The Nordic BAT group as steering group has given the needed support to fulfil the project.
- The aim is to use the results of this project as supporting material for the actual updating work of the BREF's in question. It is of great importance that the Nordic countries in a much greater extent are represented in the updated documents.
- The comments given on the present BREF's (2001) shows the need of updating these documents.
- With this contribution the document will act as a guideline for both the industry and authorities within Europe.



# Appendices

1. Working procedure in the project
2. Explanation of abbreviations and other special terminology.
3. Description of the Nordic companies having BAT-objects.



# Working procedure in the project

The working procedure decided for this project was as follows:

- The first meeting between the representatives of the Nordic BAT-group, Nils-Olov Lindfors and Pertti Kostamo was held on October 22, 2004 for:
  - Defining the main objectives for the project.
  - Defining the concept for the description of the BAT objects.
  - Defining the total timetable and the intermediate timings of the tasks. The final deadline on timetable was defined to be March 31, 2005.
- Working out the criteria for preparing and selecting of the objects.
- Working out the primary list with references of some 20 objects.
- Working out the first intermediate report, November 15, 2004.
- Carrying out the description of the objects with simultaneous discussions and choice of new references.
- The second meeting with the Nordic BAT group, was held January 12-13, 2005 (Appendix 1 gives the minutes of the meeting).
- The completion of the project.
- Working out and sending the draft final report for the project, March 15, 2005 for comments from the Nordic BAT-group.

During the whole project time, there was close and very useful cooperative work with the industrial representatives in the Nordic companies. This was of great importance to the success of this project.

The representatives from the industry were from Management-, Production-, Research and development- and Environmental departments on different levels. Also some Trade associations were contacted. Totally, more than 50 people from the industry were involved in this project.



## **Explanations for abbreviations and other special terminology**

AOD	Argon-oxygen-decarburation, converter for refining of liquid stainless steel
B	Slag basicity, mainly $\text{CaO} : \text{SiO}_2$
Bag house	Bag filter equipment for dusts (F.A. EAF-dust)
BAT	Best available technique
BF	Blast furnace, for producing of liquid hot metal
BOF	Basic oxygen furnace, converter for steelmaking from hot metal and scrap with help of oxygen blowing
BREF	BAT reference document
Burden	Raw materials inside the blast furnace (mainly coke, sinter and pellets)
Clinker	CaO-based material for cement fabrication
COD	Chemical Oxygen Demand
Coil-box	A coiling device in the rolling line. Coil-box can be equipped with mandrel or not
Coke oven	Unit for producing metallurgical coke from coal
EAF	Electric arc furnace, steelmaking from scrap with help of electric power
Gangue	Side material, mainly slag components
GJ	Gigajoule
GWh	Gigawatt hour
HDG	Hot dip galvanizing
HM	Hot metal from the blast furnace
Hot charging	Charging of the continuous casted products direct into the reheating furnace
Hot stoves	Pre-heating equipment for blast air into the blast furnace
ICP-OES	Inductively coupled plasma-optical emission spectrometry. The atoms of the component, which will be measured, are excited with plasma. The emitted radiation is measured with OES
IPPC	Integrated pollution prevention and control
LD	Process like BOF (LD = Linz and Donawitz)
LF	Ladle furnace, for refining of liquid steel
LPG	Liquid petroleum gas
MJ	Megajoule
MW	Megawatt
MWh	Megawatt hour
PAH	Polyaromatic Hydrocarbons
Passivation	To make a thin protective layer on the material surface with chemicals

PDP	Pilot demonstration plant
Pellet	9 – 16 mm round iron-oxide rich balls
Pickling	Cleaning the material surface by acids
PTFE	Teflon-type-coating on the bags
Reducing agent	Materials for reducing iron oxides to iron. The main reducing agents are coke, coal and oil
Reheating furnace	Furnace for heating of continuous casted products (slabs, blooms, billets) to rolling temperature
SCR	Selective catalytic reduction
Slag formers	Typical slag formers are CaO, SiO <sub>2</sub> and CaF <sub>2</sub> (fluospar)
Slag granulation	Producing of small slag granules from the molten BF-slag with heavy water cooling
Slag splashing	A practice, where molten slag is spread on the BOF-lining with help of inert gas blowing. Increases the lining life remarkably.
SNCR	Selective non-catalytic reduction
Soaking pit	A heating or warm-keeping furnace for ingots ore blooms
TEQ	Total Equivalent Quantity
TOC/passivation	A thin organic coating on the material
TOC/waste water	Total organic carbon

# **Descriptions of the companies and plants**

All companies and plants, from which there are objects (good examples) in this document are shortly described. It is important to note, that it is in several cases not a question of a description of the companies in total.

## **LKAB**

LKAB is a high-tech minerals group, one of the world's leading producers of highly upgraded iron ore products for the steel industry and a growing supplier of industrial minerals. The main product is pellets for crude iron production in blast furnaces and direct reduction furnaces.

LKAB's magnetite-based pellets are less energy-demanding than other iron ore products and are thereby more environmentally friendly. Most deliveries go to European steel mills. Other important markets are North Africa, the Middle East and Southeast Asia. Sales of industrial minerals are mainly to Europe, but are increasing on the Asian and US markets.

LKAB is wholly owned by the Swedish state and has more than 3 500 employees. Operations are conducted in five locations in northern Sweden and Norway. Mines and ore processing plants are located in Malmberget and Kiruna, and there is a pelletizing plant in Svappavaara and harbours in Luleå and Narvik. The Group head office is in Luleå and there are sales offices in Luleå, Brussels, Essen and Singapore

During 2003 net sales reached MSEK 7466 and deliveries of iron ore products from Kiruna and Malmberget amounted to 21.5 Mt.

## **SSAB Svenskt Stål**

SSAB is a leading producer of high-strength steel sheet and steel plate. The group comprises four subsidiaries: SSAB Tunnsplåt and SSAB Oxelösund are the steelworks businesses, Plannja is the processing company, and Tibnor is the group's trading arm. The group has a turnover of almost SEK 20 billion (2003), 9 300 employees and has operations or offices in over 40 countries and a worldwide sales presence.

### **SSAB Tunnsplåt, Sweden**

SSAB Tunnsplåt AB is the biggest steel sheet manufacturer in Scandinavia and one of Europe's leaders in the development and manufacture of high-strength steel grades.

The company has a coking plant, blast furnace and steelworks in Luleå. Three or four trainloads of slabs are shipped every day on the "Steel commuter train" from Luleå to Borlänge where the company's rolling mills and coating plants are located. SSAB Tunnsplåt also has a coil coating line in Finspång, a lamination line in Ronneby, and special steels production in Luleå. The total annual production capacity is more than 2.8 million tonnes.

SSAB Tunnsplåt is a member of the SSAB Svenskt Stål Group, has a turnover of SEK 10,6 billion (2003), and has around 4 400 employees in Borlänge, Luleå, Finspång, Ronneby and Göteborg. In addition, the company has subsidiaries in Finland, Denmark, Italy, the Netherlands and Great Britain. Profits for 2003 totalled SEK 722 million.

## SSAB Oxelösund, Sweden

SSAB Oxelösund is a member of the SSAB Svenskt Stål AB Group and is the biggest Nordic manufacturer of heavy steel plate. The company is also a world leader in the specialist field of quenched and tempered steels, and produces well-known brand names such as HARDOX and WELDOX.

SSAB Oxelösund is the only steelworks in Sweden to have an entire production line stretching from raw materials to rolled plate. The company produces around 580 000 tonnes of heavy plate, and 90 percent of the production is exported. Germany is the biggest single export market. The company has extensive stocks in more than 40 countries around the world. SSAB Oxelösund has a turnover of SEK 5.5 billion (2003), and has around 4 400 employees. Profits for 2003 totalled SEK 312 million.

## Oy OVAKO Ab

Oy Ovako Ab is a leading European producer of long special steel products for the bearing, heavy vehicle, automotive and engineering industries. Production covers low alloy and carbon steels in the form of bars, wire rod, tubes, rings, forgings and pre-components. The company has 18 production sites and several sales companies in Europe and the USA. Net sales in 2004 were EUR 1.3 billion and the company employs 5,200 people. Total steel production is 2 million tonnes.

## OVAKO Dalsbruk, Finland

Dalsbruk rolling mill consists of a reheating furnace for billets from OVAKO Koverhar and as main facility, a wire rod rolling line for wire demanding wire rod products, 5.5-21 mm in size. The production practice is mainly endless rolling with flexible coil weight. The annual production is about 0.4 million tonnes and the number of employees about 200.

## OVAKO Hofors, Sweden

Hofors steel plant is a scrap based special engineering steel producer with an annual capacity of 0,5 million tonnes. The products are seamless tubes, bars, rings, surface removed wire and further processed products. The number of employees is around 1400.

## OVAKO Imatra, Finland

Imatra Steel Works is a scrap-based producer of engineering steels for the European automotive and mechanical engineering industries. The Works' steel deliveries amounted to 243 000 tonnes in 2004. Products are low-alloyed round, square and flat bars that are supplied as rolled or heat-treated. The Steel Service Centre in Turenki is part of OVAKO Imatras organisation.

## OVAKO Koverhar, Finland

Koverhar Steel Works is an iron and ore based steel plant for producing steel billets (120x120 mm-160x160 mm, max length 12 m) with an annual production of 0.65 million tonnes. The main production facilities are one blast furnace (6.5 m, 570 m<sup>2</sup>), 2x55 tonnes combined blowing BOF-converters, a ladle furnace and two four strand continuous billet casters (120x120 mm-160x160 mm). The number of employees is 340.

## Sandvik Materials Technology, Sweden

Sandvik Materials Technology is a world leading producer of high technology stainless steels, special alloy materials and advanced value-added products, developed in close cooperation with customers.

Sandvik Materials Technology consists of five product areas: Tube, Strip, Wire, Kanthal and Process Systems.

Global presence with focus on product niches and customers with high demands on productivity, reliability, performance and cost efficiency.

Integrated production - from steel melt to finished products

About 8 000 employees

Annual sales of approximately SEK 13 000 M

Extensive investments in R&D

“The reliable partner for competitive solutions”

President: Peter Gossas

Sandvik Materials Technology is a business area within the Sandvik Group.

## Outokumpu - an international stainless steel and technology company

Outokumpu is an international stainless steel and technology company. Outokumpu's vision is to be the undisputed number one in stainless, with success based on operational excellence. Customers in a wide range of industries - from the process industry and industrial machinery to building, construction and electrical industry, transportation, electronics and information technology, as well as catering and households - use their metal products, technologies and services worldwide. Outokumpu are dedicated to helping their customers gain competitive advantage. Outokumpu call this promise the Outokumpu factor.

Outokumpu operates in more than 40 countries and employs some 19 000 people. Annual sales exceed 6 billion €, of which more than 90 percent is generated outside Finland. The Group's headquarters is located in Espoo, Finland. The parent company, Outokumpu Oyj, has been listed on the Helsinki stock exchange since 1988.

## **Outokumpu Stainless**

The demand and consumption of stainless steel grows faster than any other metal in the world. Outokumpu Stainless is one of the largest producers of stainless steel and widely recognized as a world leader in technical support, research and development.

Outokumpu Stainless' plants, mainly situated in Finland, Sweden, Britain and the U.S., produce a wide range of stainless steel products including hot and cold rolled coil, sheet and plate, precision strip as well as tubular and long products. Additionally, their customers gain a comprehensive selection of fittings, flanges and welding consumables. Outokumpu's products are available in various dimensions, grades and surface finishes. Outokumpu produces part of its own raw material in the Outokumpu chromium mine and ferrochrome facility.

The excellent qualities of stainless steel make it the ideal choice in various demanding industrial and end-use applications such as food processing, chemical industries, oil platforms and constructions, automotive, cutlery and razor blades.

The annual sales of Outokumpu Stainless exceed 4 billion € and the operation employs some 9 200 persons.

## Coil Products

The Coil Products division is Outokumpu Stainless' core business and consists of the steel melting and coil processing systems in Tornio in Finland, at Avesta, Nyby and Kloster in Sweden and in Sheffield in the UK. These facilities are being integrated and developed to create a world-leading production system distinguished by high quality and cost efficiency.

In their various forms, Cold Rolled Products are used in a wide variety of end uses, ranging from providing corrosion resistant solutions for the process industry, to polished strip for consumer durables, to patterned sheet for prestigious buildings or other architectural applications. Due to their excellent dimensional tolerances and high surface quality, cold rolled products are the predominant category of stainless steels currently used on the market.

Semi-Cold Rolled Products provide a surface quality similar to that found in hot rolled products, but their thickness tolerances are closer to those achieved for cold rolled products. This type of material is particularly popular for producing tubular products in both process industry and structural applications and also re-rolling.

Hot Rolled Products are used in many applications in the production of process plant equipment. They are also used as feedstock in the manufacture of cold rolled flat products, tubes and bar.

Our production units can supply material directly to the customer, or through one of our own service centres. The Coil Products business units utilise the Outokumpu network of sales companies as well as independent agents for the distribution and sale of their products. The mills also have sales personnel who co-operate closely with sales company staff and customers.

Outokumpu Stainless has its own research centres that help the sales network in product properties and their applications. The research centres are located in Avesta, Sweden and Tornio, Finland.

## Ruukki

Ruukki supplies components, systems and total solutions to the construction and mechanical engineering industries. The company has a wide selection of products and services in metal products. Ruukki has operations in 24 countries and employs 12 000 people. Net sales in 2004 totalled EUR 3.6 billion. The company's share is quoted on the Helsinki Exchanges (Rautaruukki Corporation: RTRKS).

Ruukki produces steel in an ore based integrated steelworks at Raahe (2.8 Mt/a), an ore based integrated steelworks at Koverhar (0.6 Mt/a), a scrap based steelworks at Smedjebacken (0.5 Mt/a) and a scrap based steelworks at Mo i Rana (0.7 Mt/a). The products from units at Raahe, Hämeenlinna, Kankaanpää, Taalintehdas, Nedstaal, Smedjebacken, Boxholm and Mo i Rana are hot rolled strips 0.6 Mt/a, steel plates 0.3 Mt/a, galvanized strips 0.6 Mt/a, cold rolled strips 0.2 Mt/a, colour coated strips 0.3 Mt/a, tubes 0.4 Mt/a, wire rods 0.6 Mt/a, bars 0.5 Mt/a, reinforcing 0.5 Mt/a and steel billets 0.15 Mt/a.

## Raahe Steel Works, Finland

Ruukki is composed of three customer oriented divisions and a production division, Ruukki Production to which the Raahe Steel Works belongs. Raahe Steel Works is the largest steel works in the Nordic countries and one of the largest industrial sites in Finland. At the end of 2004 there were about 3 150 employees at Raahe Steel Works. In addition there are outside contractors also working on the sites.

Raahe Steel Works is an integrated steel production plant for flat products (strips and plates) with an annual production of 2.8 million tonnes. The main production facilities comprise a coking plant, 2 blast furnaces, a sinter plant, 3x120 ton combined blown converters, a ladle furnace and a tank degasser and 4 single strand continuous casters.

Ruukki Production's plate mill at Raahe Steel Works is equipped with a single four-high reversing stand, used to produce heavy plates from continuously cast slabs. The rolling capacity of the plate mill is about 0.7 Mt/a. Plates are supplied to clients in the business areas ship-building and offshore, mechanical engineering and steel construction, as well as to trading and steel service centres.

Ruukki Production's 6-stand hot strip mill at Raahe Steel Works rolls 2.3 million tonnes per year of coiled plate. This unit produces hot-rolled sheets, slit coils and pickled coils.

## Hämeenlinna Works, Finland

Hot strip, the raw material for the Hämeenlinna Works, is delivered by rail from Raahe Steel Works, where Ruukki Production has a cold rolling mill with galvanizing lines and colour coating lines. The products cold-rolled, hot-dip galvanized and coil-coated products are transported by road to domestic customers; export deliveries are transported by rail from the works to the harbours. The work's annual output amounts to 1.25 million tonnes of strip products, more than a half being exported.

## Mo Steel Works, Norway

Mo Steel Works is a scrap-based steel plant with one 100 ton electric arc furnace, one ladle furnace, one continuous caster for billets (160x160 mm) and a rolling mill for rebar, rebar coils and mesh wire rod. The annual production is about 0.7 million tonnes and the number of employees about 3 500.

## Dansk Overflade Teknik A/S (DOT), Denmark

Dansk Overflade Teknik A/S (DOT) was established in 2002 by the merging of Herning Galvanisering A/S, Dansk Overfladeteknik A/S in Fæstervang, FJ Varmforzinkning A/S in Ferritslev, FJ Varmforzinkning A/S in Køge and later in 2003 by taking over Middelfart Galvanisering A/S.

On May 13, 2004 the production in Middelfart was moved to the plants in Fæstervang and Ferritslev, after which the entire production in Middelfart has stopped. Having four production plants in all, two in Fæstervang, one in Ferritslev and one in Køge we are close to our customers in Denmark, Southern Sweden and Northern Germany. Apart from the above mentioned, DOT owns two companies in Sweden, JIWE Varmförzinkning in Sölvesborg and JIWE Varmförzinkning in Eskilstuna. DOT has about 550 employees.

The fact that the individual production units more or less offer the same core services makes it possible for DOT to ensure a high quality level, based on great flexibility and short times of delivery. The large, uniform production volume also makes it possible for us to implement innovation programmes in order to improve our production capacity and competitiveness.

DOT is certified both in accordance with the quality management system DS/EN ISO 9001 and the environmental management system DS/EN ISO 14001 and is continuously working to improve its goals in these two areas.

### JIWE Varmförszinkning AB, Sweden

JIWE Varmförszinkning AB is the biggest hot dip galvanizer in Sweden with two plants, one in Sölvesborg in the south of Sweden and one in Eskilstuna in central Sweden. The company has 120 employees and an annual turnover of approximately 90 MSEK. The plant in Sölvesborg comprises two highly automated low temperature lines that were built in 2003-2004 after a disastrous fire that destroyed the earlier two lines.

### The Ørsta Group, Norway

The Ørsta Group Ltd. is a supplier of products and systems where corrosion-protected steel are significant components. The main fields of business are:

- Marine installations: Marinas and aquaculture facilities.
- Infrastructure: Road lighting, road safety, rock support, tunnel lining, street furniture, power lines installations, building and constructions.

The Ørsta Groups companies are localised in Norway, Sweden, Poland and France. Annual turnover is ca 420 million NOK and number of employees is about 400.

Ørsta Stål AS is the biggest company of the group, localised in Ørsta in Norway (in the Western part). Manufacturer of purchased steel as pipes, sheets, profiles etc to different kind of products. Laser and robot technology and plants for hot dip galvanizing and powder coating of the products (Combi-Coat<sup>®</sup>). About 220 employees.

### Galvanoimis Oy, Finland

Galvanoimis Oy is a hot dip galvanizing company located in South Finland. The annual turnover is about 10 million € and the number employees is about 100.

The main production facility consists of two galvanizing tanks in a building of 9 300 m<sup>2</sup>. A closed hot dip galvanizing process is developed by the company.

The products are different types of galvanized steel structures.



*Lista sätts in av NMS.*